



MARTIN COUNTY STANDARD DETAILS FOR ROAD & SITE CONSTRUCTION AND PUBLIC FACILITIES

Effective: APRIL 23, 2019

APPROVED BY
MARTIN COUNTY BOARD OF COUNTY COMMISSIONERS

EDWARD V. CIAMPI	CHAIRMAN
HAROLD E. JENKINS II	VICE CHAIRMAN
STACEY HETHERINGTON	COMMISSIONER
SARAH HEARD	COMMISSIONER
DOUG SMITH	COMMISSIONER

LISA A. WICHSER, P.E., CFM – COUNTY ENGINEER

STATEMENT OF INTENT

THE REQUIREMENTS SET FORTH IN THIS DOCUMENT ARE INTENDED TO PROVIDE A BASIS OF DESIGN AND CONSTRUCTION. ANY VARIATION FROM STANDARDS MUST BE APPROVED IN ADVANCE BY THE COUNTY ENGINEER OR HIS/HER DESIGNATED REPRESENTATIVE HEREINAFTER KNOW AS "COUNTY ENGINEER". THE ROADS & SITE CONSTRUCTION DETAILS SHALL BE APPLICABLE IN ALL CASES WHERE THOSE PORTIONS OF CONSTRUCTION LIE OR WILL LIE WITHIN THE PUBLIC OR PRIVATE RIGHTS-OF-WAY OF MARTIN COUNTY. THE PUBLIC FACILITIES DETAILS SHALL BE APPLICABLE IN ALL CASES WHERE THE FACILITIES BEING PROVIDED OR CONSTRUCTED ARE OWNED AND/OR OPERATED AND MAINTAINED BY MARTIN COUNTY. IT IS NOT NECESSARILY INTENDED THAT THE PUBLIC FACILITIES DETAILS BE APPLICABLE IN CASES WHERE THE FACILITIES BEING PROVIDED OR CONSTRUCTED ARE OWNED AND/OR OPERATED BY A PRIVATE ENTITY.

TABLE OF CONTENTS

DETAIL NUMBER	DESCRIPTION
	<u>ROAD & SITE CONSTRUCTION DETAILS</u>
R-10	FLEXIBLE PAVEMENT
R-20	PERVIOUS PAVEMENT
R-30	PAVEMENT WIDENING
R-31A	OPEN CUT TRENCH
R-31B	OPEN CUT TRENCH – NOTES
R-35	MITERED END SECTION
R-38	RIP RAP
R-39	STABILIZED CONSTRUCTION ENTRANCE
R-40	CURB & GUTTER
R-41	SIDEWALK
R-42	SIDEWALK REPLACEMENT/REPAIR
R-43	MEANDERING SIDEWALK
R-50	LOCAL ROAD INLET
R-51	VALLEY GUTTER INLET
R-60	PIPE STRUCTURE CONNECTION
R-70	STORM DRAIN PIPE AND PIPE JOINT
R-80	TURF BLOCK
R-81	BACK-IN PARKING
R-90A	ROAD END TREATMENT (CUL-DE-SAC)
R-90B	ROAD END TREATMENT (TURNAROUNDS)
R-91A	RESIDENTIAL DRIVEWAY – CULVERT
R-91B	RESIDENTIAL DRIVEWAY – INVERT
R-100	TREE GRATE
R-110A	TRAFFIC CALMING (SPEED TABLE)
R-110B	TRAFFIC CALMING (SPLITTER ISLAND)
R-120A	CROSSWALK
R-120B	CROSSWALK (STAMPED)
R-130	STREET LIGHT
R-140A	TRAFFIC CONTROL
R-140B	TRAFFIC CONTROL
R-140C	TRAFFIC CONTROL
R-140D	TRAFFIC CONTROL
R-150A	TRAFFIC SIGNAL SPECIFICATIONS
R-150B	TRAFFIC SIGNAL SPECIFICATIONS
R-150C	TRAFFIC SIGNAL SPECIFICATIONS

TABLE OF CONTENTS

DETAIL NUMBER	DESCRIPTION
R-150D	TRAFFIC SIGNAL SPECIFICATIONS
R-160A	FIBER OPTIC CONDUIT (PLAN)
R-160B	FIBER OPTIC CONDUIT (PROFILE)
R-170	FLASHING BEACON
R-171	EDGE LIT SIGN
R-180A	CCTV (MAST ARM MOUNT)
R-180B	CCTV (CONCRETE POLE MOUNT)
R-190A	TRAFFIC MONITORING SITE (LAYOUT)
R-190B	TRAFFIC MONITORING SITE (COUNTER PAD)
R-190C	TRAFFIC MONITORING SITE (POLE-MOUNTED CABINET)
R-190D	TRAFFIC MONITORING SITE (POLE-MOUNTED CABINET)

PUBLIC FACILITIES DETAILS

P-15	FIXED BOLLARD
P-20A	DUMPSTER ENCLOSURE
P-20B	DUMPSTER ENCLOSURE
P-30	BICYCLE RACK
P-40	PRESERVE AREA SIGN
P-50	EQUESTRIAN TRAIL
P-51	EQUESTRIAN TRAIL - 'V' GATE
P-60	POST AND RAIL FENCE
P-61	POST AND RAIL FENCE - DOUBLE SWING GATE
P-62	POST AND RAIL FENCE - FENCE OPENING

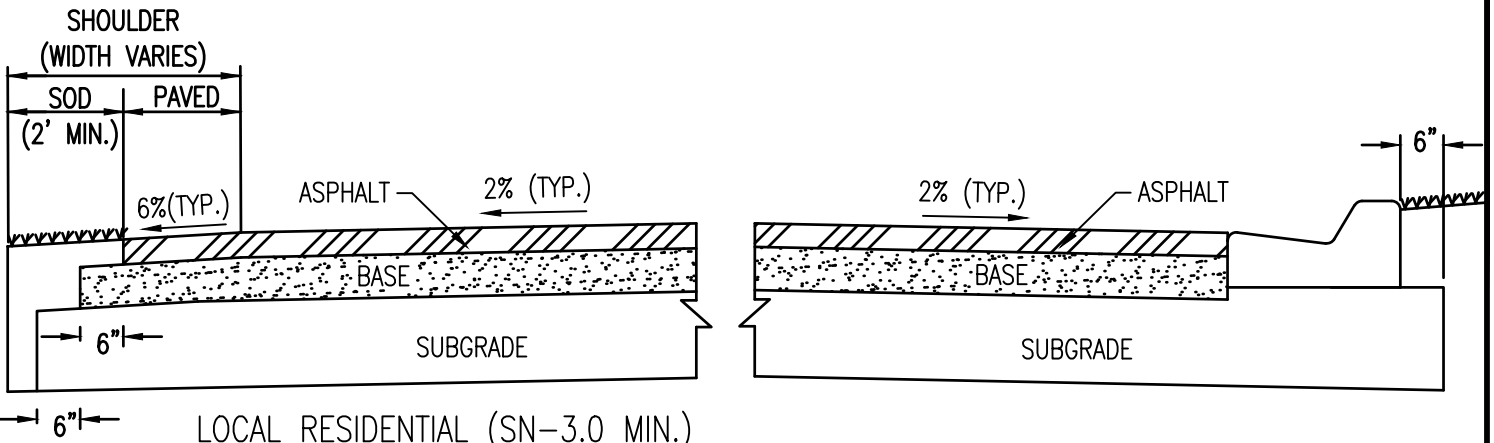

LOCAL RESIDENTIAL (SN-3.0 MIN.)

MIN. E.O.P. ELEVATION > PEAK STAGE OF 10-YR / 24-HR STORM EVENT

- SURFACE COURSE: 1½" TYPE SP-9.5 ASPHALTIC CONCRETE
- BASE COURSE: OPTIONAL BASE GROUP 6 PER FDOT FLEXIBLE PAVEMENT DESIGN MANUAL TABLE 5.6
- SUBGRADE: 12" COMPACTED OR STABILIZED SUBGRADE (LBR-40)

COLLECTOR & LOCAL COMMERCIAL/INDUSTRIAL (SN-3.5 MIN.)

MIN. E.O.P. ELEVATION > PEAK STAGE OF 10-YR / 24-HR STORM EVENT (MINOR)

MIN. E.O.P. ELEVATION > PEAK STAGE OF 25-YR / 24-HR STORM EVENT (MAJOR)

- SURFACE COURSE 1½" TYPE SP-12.5 ASPHALTIC CONCRETE (1ST LIFT)
1" TYPE SP-9.5 ASPHALTIC CONCRETE (2ND LIFT)
- BASE COURSE: OPTIONAL BASE GROUP 6 PER FDOT FLEXIBLE PAVEMENT DESIGN MANUAL TABLE 5.6
- SUBGRADE: 12" COMPACTED OR STABILIZED SUBGRADE (LBR-40)

ARTERIAL (SN-4.0 MIN.)

MIN. E.O.P. ELEVATION > PEAK STAGE OF 25-YR / 72-HR STORM EVENT

- SURFACE COURSE 2" TYPE S-1 OR SP-12.5 ASPHALTIC CONCRETE (1ST LIFT)
1" TYPE SP-9.5 ASPHALTIC CONCRETE (2ND LIFT)
- BASE COURSE: OPTIONAL BASE GROUP 9 PER FDOT FLEXIBLE PAVEMENT DESIGN MANUAL TABLE 5.6
- SUBGRADE: 12" COMPACTED OR STABILIZED SUBGRADE (LBR-40)

NOTES:

- SHOULDER DESIGN:
 - SURFACE COURSE: SAME AS TRAVEL LANE SURFACE COURSE
 - BASE COURSE: OPTIONAL BASE GROUP 4 PER FDOT FLEXIBLE PAVEMENT DESIGN MANUAL TABLE 5.6
- STRUCTURAL NUMBER (SN) PER FDOT STANDARDS (REFER TO FDOT FLEXIBLE PAVEMENT DESIGN MANUAL).
- SUBSTITUTIONS MAY BE APPROVED BY MARTIN COUNTY, PROVIDED MINIMUM SN IS DEMONSTRATED.
- ASPHALT MIX SHALL NOT CONTAIN MORE THAN 30% RECLAIMED ASPHALT PAVEMENT (R.A.P.)
- ALL MATERIAL USED WITHIN THE ROADWAY MUST MEET FDOT SPECIFICATIONS AND BE SUPPLIED FROM A FDOT CERTIFIED MINING OPERATION AND ASPHALT PLANT.
- A MINIMUM OF TWO DENSITY TESTS SHALL BE TAKEN FOR EACH SIX (6) INCH LIFT OF SUB GRADE AND BASE. WHEN THE SPECIFIED COMPACTED BASE IS GREATER THAN SIX AND ONE-HALF (6 ½") INCHES THE BASE SHALL BE CONSTRUCTED IN TWO OR MORE COURSES. PROCTORS FOR MATERIALS USED IN BACK-FILLING SHALL BE OBTAINED BY A CERTIFIED LABORATORY. DENSITY TESTS SHALL BE CONDUCTED BY A CERTIFIED LABORATORY. THE PERCENTAGE OF MAXIMUM DENSITY REQUIRED SHALL BE IN ACCORDANCE WITH THE LATEST EDITION OF THE FLORIDA DEPARTMENT OF TRANSPORTATION STANDARD SPECIFICATIONS. A COPY OF ALL COMPLETED AND ACCEPTED DENSITY TESTS SHALL BE FURNISHED TO THE COUNTY ENGINEER'S OFFICE PRIOR TO FINAL INSPECTION.
- CRUSHED CONCRETE MAY NOT BE USED WITHIN COUNTY-MAINTAINED ROADWAY.
- ANY IN-LINE PARKING DEFICIENCIES SHALL BE ADDRESSED IN ACCORDANCE TO FDOT SPECIFICATION SECTION 330.



MARTIN COUNTY PUBLIC WORKS - STANDARD DETAILS

FLEXIBLE PAVEMENT

DETAIL

R-10

DATE: 04/23/19

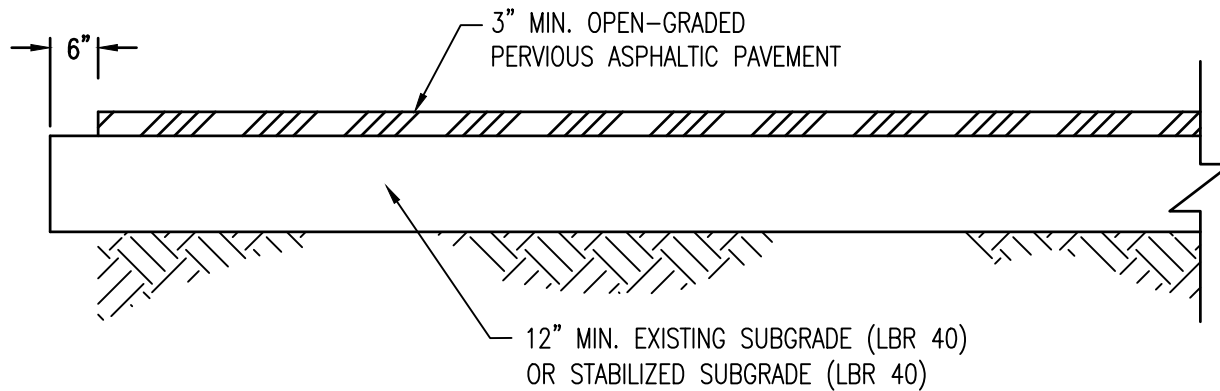

PERVIOUS ASPHALTIC PAVEMENT SECTION

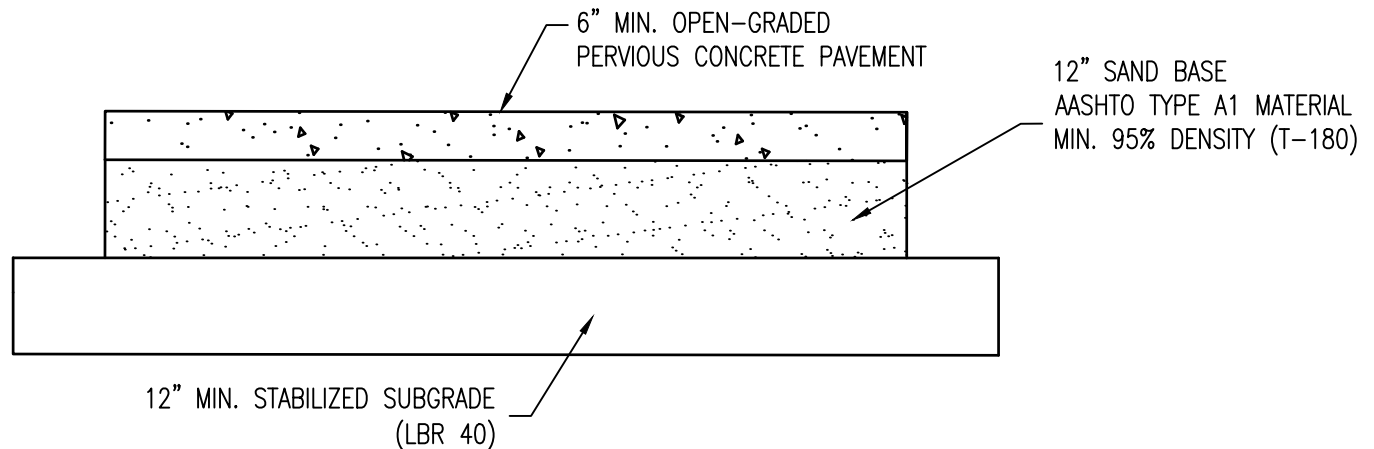

PERVIOUS CONCRETE PAVEMENT SECTION

NOTES:

1. THE PERVIOUS PAVEMENT CONTRACTOR SHALL BE APPROVED BY THE COUNTY ENGINEER AND MUST BE CERTIFIED BY THE NATIONAL READY MIX CONCRETE ASSOCIATION (NRMCA).
2. THE CONTRACTOR SHALL SUBMIT A PERVIOUS PAVEMENT MIX DESIGN TO THE COUNTY ENGINEER FOR APPROVAL.
3. PERVIOUS CONCRETE MIX SHALL HAVE 20% TO 25% VOIDS, AN AGGREGATE TO CEMENT (A/C) RATIO BETWEEN 4.0 AND 4.5, AND A WATER TO CEMENT (W/C) RATIO BETWEEN 0.27 AND 0.36.
4. ALL MATERIAL USED WITHIN THE ROADWAY MUST MEET FDOT SPECIFICATIONS AND BE SUPPLIED FROM A FDOT CERTIFIED MINING OPERATION AND ASPHALT PLANT.
5. A MINIMUM OF TWO DENSITY TESTS SHALL BE TAKEN FOR EACH SIX (6) INCH LIFT OF SUB GRADE AND BASE. WHEN THE SPECIFIED COMPACTED BASE IS GREATER THAN SIX AND ONE-HALF (6 ½") INCHES THE BASE SHALL BE CONSTRUCTED IN TWO OR MORE COURSES. PROCTORS FOR MATERIALS USED IN BACK-FILLING SHALL BE OBTAINED BY A CERTIFIED LABORATORY. DENSITY TESTS SHALL BE CONDUCTED BY A CERTIFIED LABORATORY. THE PERCENTAGE OF MAXIMUM DENSITY REQUIRED SHALL BE IN ACCORDANCE WITH THE LATEST EDITION OF THE FLORIDA DEPARTMENT OF TRANSPORTATION STANDARD SPECIFICATIONS. A COPY OF ALL COMPLETED AND ACCEPTED DENSITY TESTS SHALL BE FURNISHED TO THE COUNTY ENGINEER'S OFFICE PRIOR TO FINAL INSPECTION.
6. CRUSHED CONCRETE MAY NOT BE USED WITHIN COUNTY-MAINTAINED ROADWAY.



MARTIN COUNTY PUBLIC WORKS - STANDARD DETAILS

PERVIOUS PAVEMENT

DETAIL

R-20

DATE: 04/23/19

ADDITION OF A RIGHT TURN LANE OR SHOULDER:

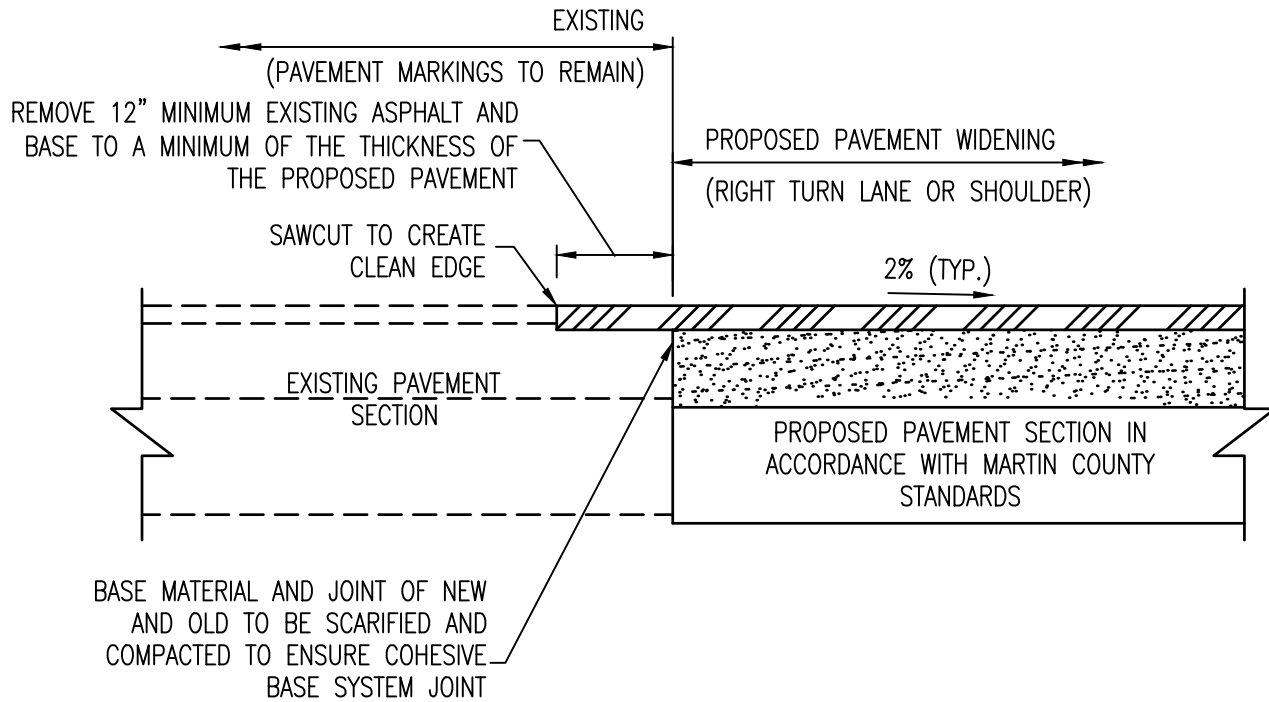

OTHER PAVEMENT ADDITIONS:

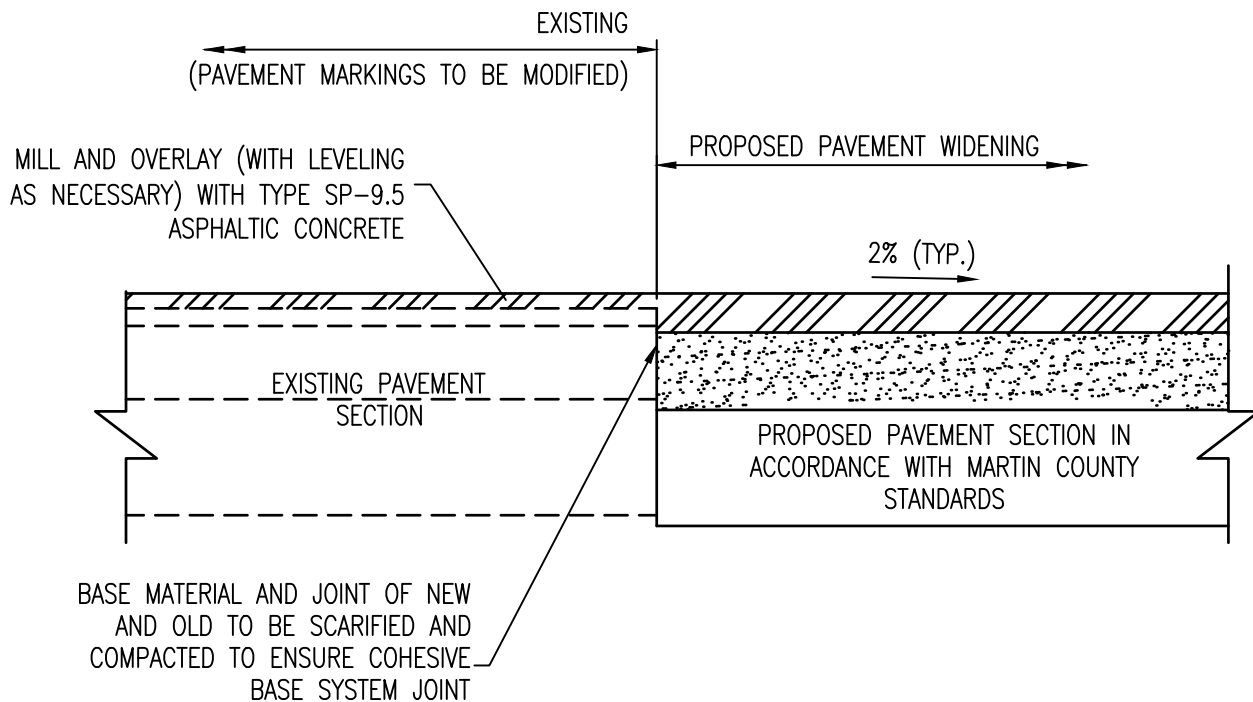

MARTIN COUNTY PUBLIC WORKS - STANDARD DETAILS

PAVEMENT WIDENING

DETAIL

R-30

DATE: 04/23/19

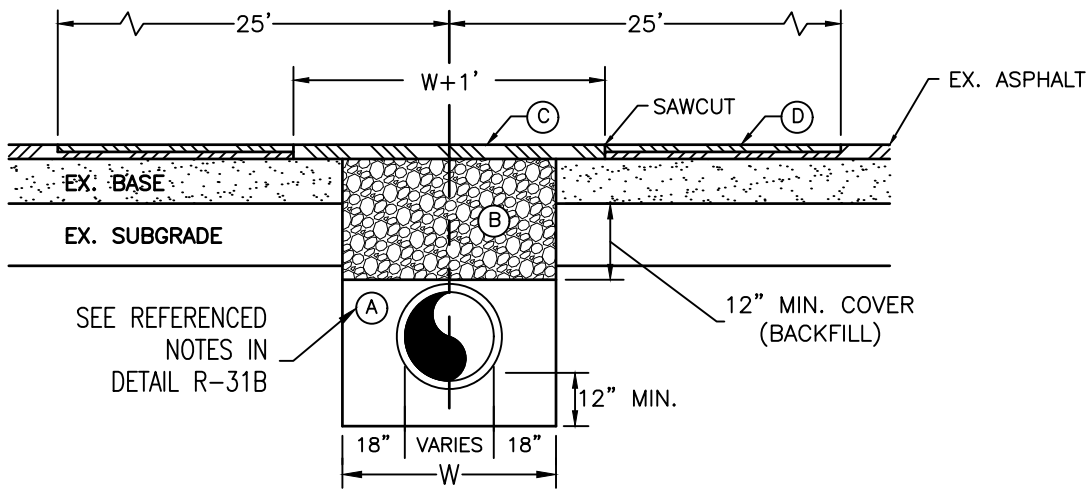

TRENCH DETAIL WITH PAVEMENT OVERLAY
N.T.S.

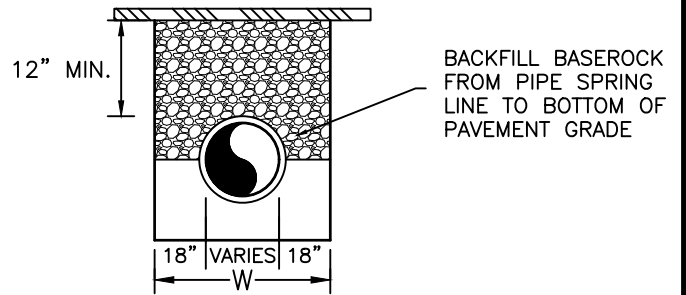

PIPE WITHIN BASEROCK
N.T.S.

BACKFILL SELECT MATERIAL FROM PIPE SPRING LINE TO SURFACE GRADE IN 12" MAXIMUM LIFTS. EACH LIFT TO BE MECHANICALLY TAMPED TO A MINIMUM 100% OF MAX. DENSITY AS DETERMINED BY AASHTO METHOD T-99 FOR NON-FLEXIBLE PIPE (RCP, DIP) AND 98% FOR FLEXIBLE PIPE.

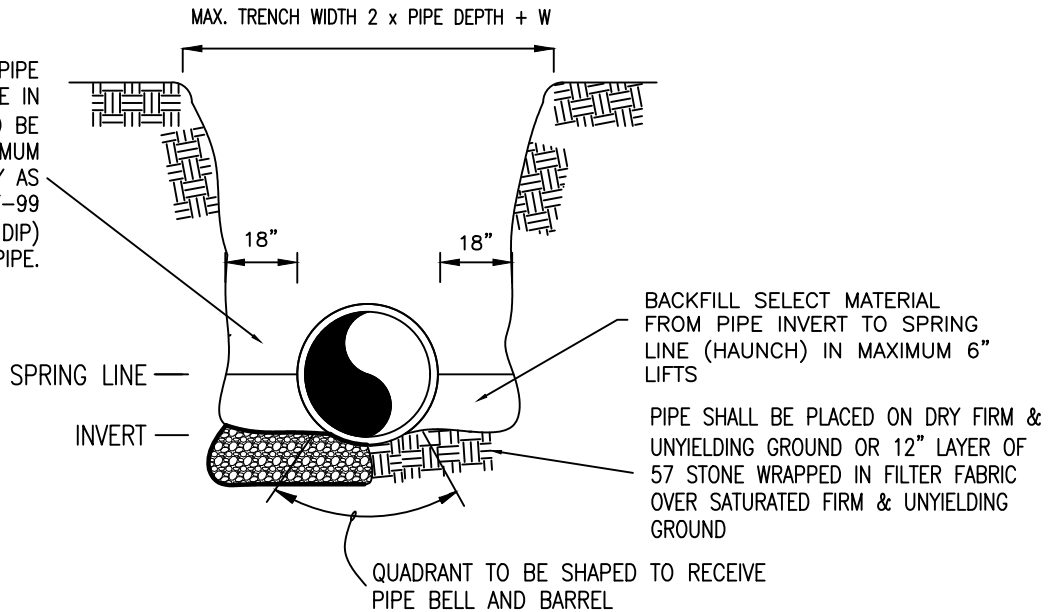

TRENCH DETAIL
N.T.S.

NOTES:

SEE SPECIFICATIONS & NOTES ON DETAIL R-31B



MARTIN COUNTY PUBLIC WORKS - STANDARD DETAILS

TYPICAL OPEN CUT TRENCH

DETAIL

R-31A

DATE: 04/23/19

BACKFILL AND BASE

- A. PROVIDE CLEAN BACKFILL. BACKFILL SHALL BE REPLACED IN 12" LIFTS. EACH LIFT SHALL BE MECHANICALLY COMPACTED TO A MINIMUM 100% DENSITY AS DETERMINED BY AASHTO T-180, METHOD "C" (MINIMUM LBR OF 40).
- B. BASE ROCK MATERIAL SHALL BE A MINIMUM OF 2' THICK AND BE PLACED IN 6" LIFTS OR AS OTHERWISE APPROVED AND EACH LAYER THOROUGHLY MECHANICALLY COMPACTED TO 100% DENSITY AS DETERMINED BY AASHTO T-180. ALL BASE MATERIAL MUST MEET FDOT SPECIFICATIONS FROM A CERTIFIED MINING OPERATION. DEPTH OF BASE MATERIAL VARIES ON ROADWAY TYPE AS PER MARTIN COUNTY PUBLIC WORKS STANDARD DETAIL R-10.

PAVING

- A. A TEMPORARY PATCH SHALL BE NO LESS THAN 2" THICK OR MATCH EXISTING PAVEMENT THICKNESS, WHICHEVER IS GREATER. ASPHALT PATCHES MUST BE OF A HOT MIX TYPE FRICTION COURSES. MARTIN COUNTY DOES NOT ALLOW COLD PATCH IN COUNTY MAINTAINED ROADWAYS. THE PATCH IS TO REMAIN 30 DAYS AT MINIMUM TO ASSURE ANY SETTling OF THE ROADWAY TRENCH HAS TAKEN PLACE.
- B. MILL 1" OF ASPHALT A MINIMUM OF 25' FROM CENTER OF TRENCH ON BOTH SIDES, SEE NOTE #1. PAVE AND COMPACT 1" OF SP-9.5 OR MATCH EXISTING TYPE OF FRICTION COURSE.
- C. WHEN OPEN CUT IS PARALLEL TO TRAVEL LANE, THE FULL ROADWAY SECTION IS REQUIRED TO BE RESURFACED 10' BEYOND TRENCH IN EACH DIRECTION OF TRAVEL.
- D. ASPHALT MIX TO CONTAIN NO MORE THAN 30% RECLAIMED ASPHALT PAVEMENT (R.A.P.).
- E. ASPHALT PAVEMENT PATCH SHALL BE PLACED WITHIN 72 HOURS AFTER TRENCH HAS BEEN BACKFILLED.

NOTES:

- 1. ANY OPEN CUT OF PAVEMENT MUST BE REVIEWED BY THE COUNTY ENGINEER PRIOR TO ANY WORK BEING DONE IN COUNTY MAINTAINED RIGHT-OF-WAY. DEPENDING ON THE LOCATION OF THE OPEN CUT ADDITIONAL MILLING AND PAVING MAY BE REQUIRED; ALL PAVEMENT JOINTS SHALL BE MECHANICALLY SAWED.
- 2. ALL MATERIAL USED WITHIN THE ROADWAY MUST MEET FDOT SPECIFICATIONS AND BE SUPPLIED FROM A FDOT CERTIFIED MINING OPERATION AND ASPHALT PLANT.
- 3. A MINIMUM OF TWO DENSITY TESTS SHALL BE TAKEN FOR EACH SIX (6) INCH LIFT OF SUB GRADE AND EACH OPEN CUT CROSSING. WHEN THE SPECIFIED COMPACTED BASE IS GREATER THAN SIX AND ONE-HALF (6 ½") INCHES THE BASE SHALL BE CONSTRUCTED IN TWO OR MORE COURSES. PROCTORS FOR MATERIALS USED IN BACK-FILLING SHALL BE OBTAINED BY A CERTIFIED LABORATORY. DENSITY TESTS SHALL BE CONDUCTED BY A CERTIFIED LABORATORY. THE PERCENTAGE OF MAXIMUM DENSITY REQUIRED SHALL BE IN ACCORDANCE WITH THE LATEST EDITION OF THE FLORIDA DEPARTMENT OF TRANSPORTATION STANDARD SPECIFICATIONS. A COPY OF ALL COMPLETED AND ACCEPTED DENSITY TESTS SHALL BE FURNISHED TO THE COUNTY ENGINEER'S OFFICE PRIOR TO FINAL INSPECTION.
- 4. CRUSHED CONCRETE MAY NOT BE USED WITHIN COUNTY-MAINTAINED ROADWAY.



MARTIN COUNTY PUBLIC WORKS - STANDARD DETAILS

TYPICAL OPEN CUT TRENCH

DETAIL

R-31B

DATE: 04/23/19

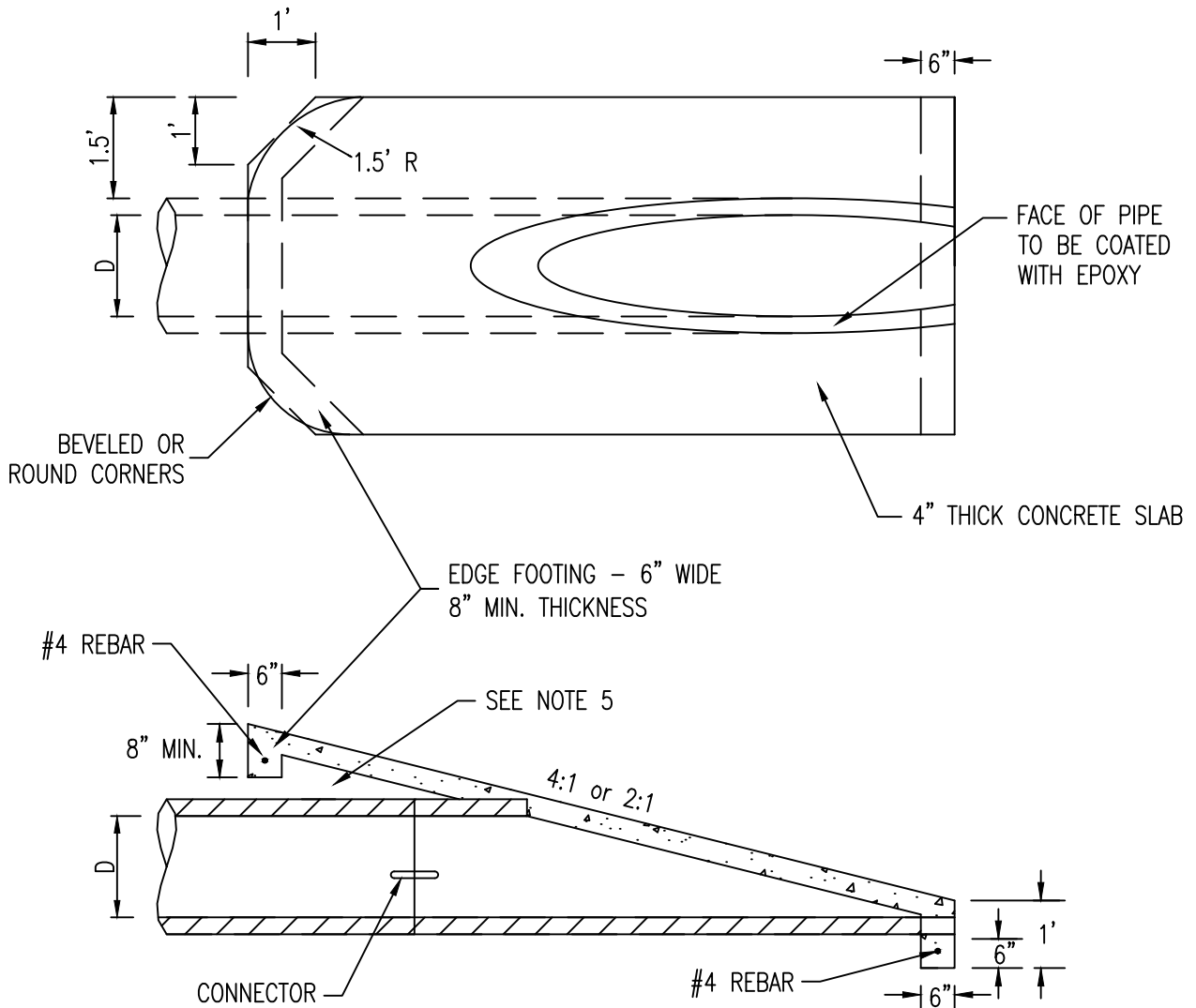

NOTES:

1. SLAB CONCRETE SHALL BE STRUCTURAL 3000 PSI
2. SLAB SHALL CONSIST OF WWF 6x6-W1.4 THERMAL REINFORCEMENT TIED INTO BOTTOM FOOTER OR FIBERMESH
3. TOP AND BOTTOM EDGES SHALL HAVE 6" WIDE THICKENED FOOTER PER SPECIFIED DIMENSIONS WITH #4 REBAR
4. THE MITRED/CUT FACE OF THE PIPE SHALL BE COATED WITH A HIGH-BUILD, PROTECTIVE, SOLVENT-FREE, COLORED EPOXY COATING (SIKA SIKAGARD 62 EPOXY COATING OR EQUIVALENT APPROVED BY THE COUNTY ENGINEER).
5. TOP EDGE FOOTING SHALL BE A MINIMUM OF 8" THICK WITH #4 REBAR IN BOTTOM 4" OF FOOTING. THE CAVITY BETWEEN PIPE AND SLAB/FOOTING SHALL BE FILLED WITH CLEAN BACKFILL, COMPACTED TO A MINIMUM 100% DENSITY AS DETERMINED BY AASHTO T-180, METHOD "C". WHEN BOTTOM OF 8" EDGE FOOTING IS ON PIPE, FILL CAVITY BETWEEN PIPE AND SLAB/FOOTING WITH CONCRETE.



MARTIN COUNTY PUBLIC WORKS - STANDARD DETAILS

MITERED END SECTION

DETAIL

R-35

DATE: 04/23/19

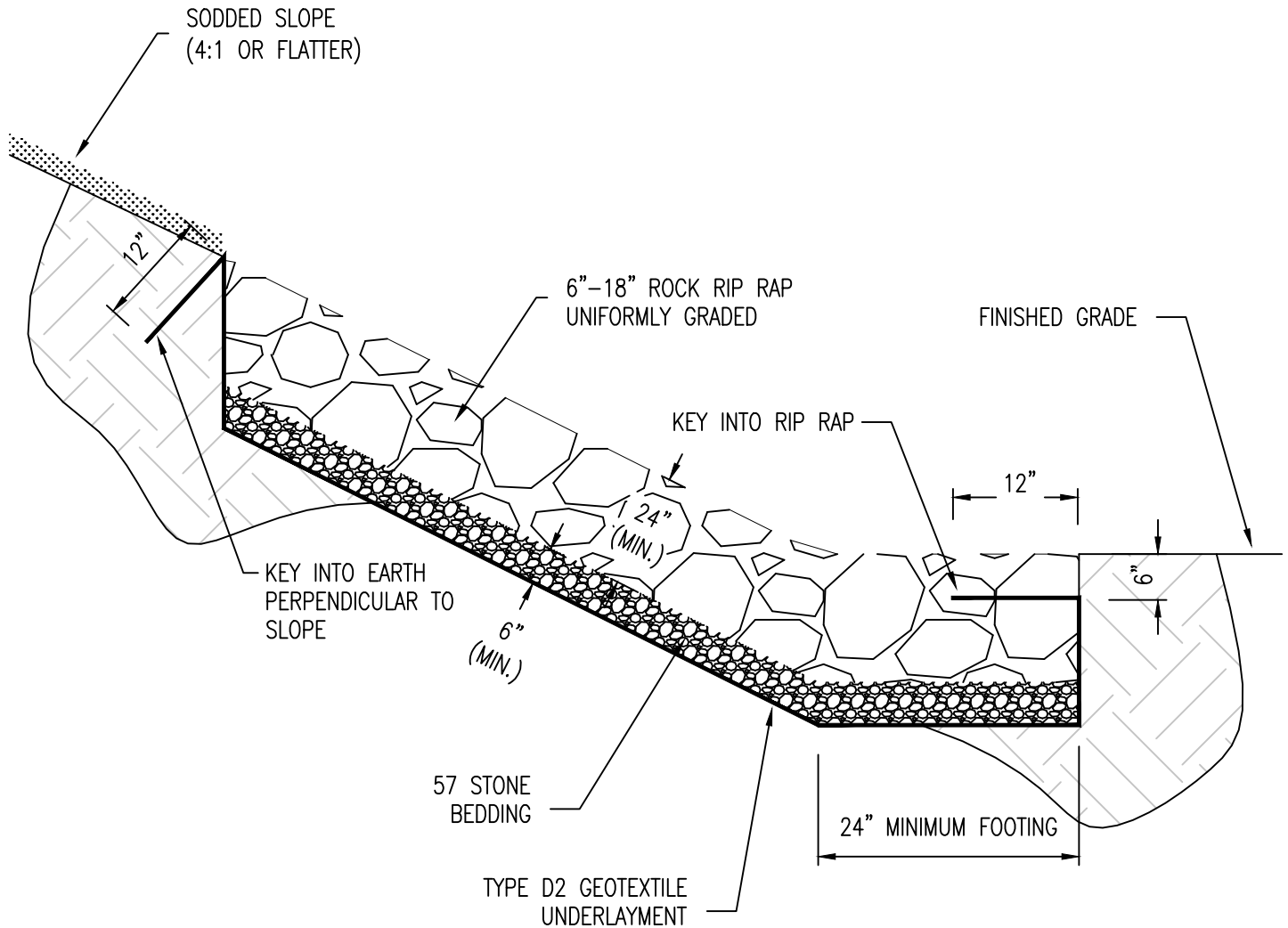

NOTES:

1. RIP RAP SHALL HAVE 6" MINIMUM FDOT #57 STONE BEDDING OVER TYPE D2 GEOTEXTILE UNDERLAYMENT. AT THE DISCRETION OF THE COUNTY ENGINEER, STONE BEDDING MAY BE OMITTED FOR HAND-PLACED RIP RAP INSTALLATION IF THE WORK IS SUPERVISED BY COUNTY REPRESENTATIVES.
2. RIP RAP SHALL BE COQUINA ROCK (MINIMUM SPECIFIC GRAVITY ≥ 2.3) UNIFORMLY GRADED AND TIGHTLY INTERLOCKED.
3. TYPE D2 GEOTEXTILE SHALL BE KEYED INTO THE NATURAL EARTH AT THE TOP OF BANK AND KEYED INTO THE RIP RAP AT THE TOE OF SLOPE, A MINIMUM OF 12".
4. RIP RAP SHALL BE WASHED FREE OF FINE SEDIMENTATION PRIOR TO PLACEMENT.



MARTIN COUNTY PUBLIC WORKS - STANDARD DETAILS

RIP RAP INSTALLATION

DETAIL

R-38

DATE: 04/23/19

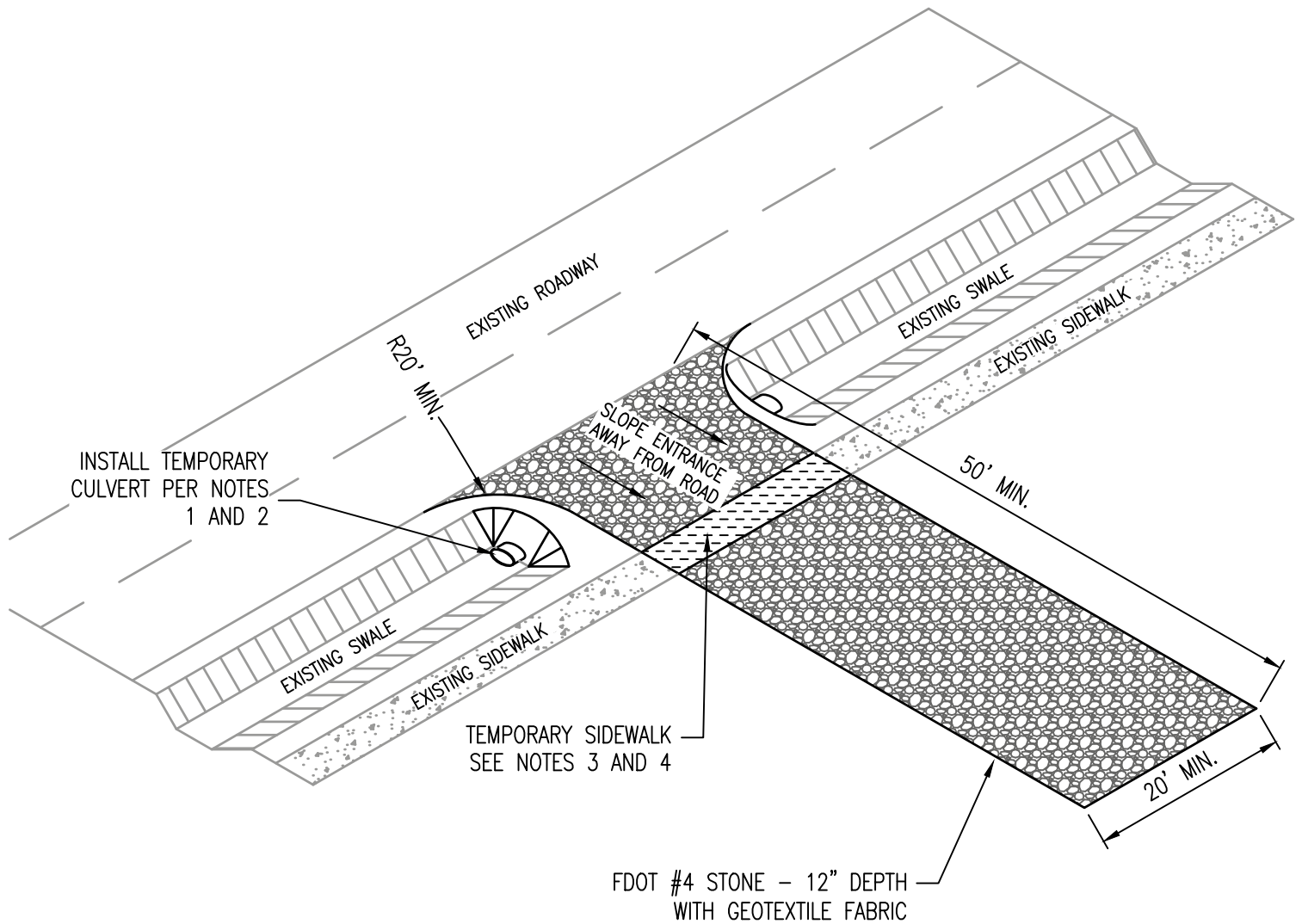

NOTES:

1. CULVERT INVERTS SHALL MATCH THE DRAINAGE CONVEYANCE FLOW LINE OF UPSTREAM AND DOWNSTREAM CULVERT INVERTS.
2. CULVERT SIZE SHALL BE EQUIVALENT OR GREATER THAN UPSTREAM CULVERT OR MIN. 15" DIA. (OR 12"x18" ELLIPTICAL)
3. TEMPORARY SIDEWALK MATERIALS TO BE EITHER: PORTLAND CEMENT CONCRETE, ASPHALT CONCRETE, COMPACTED ASPHALT MILLINGS, OR COMPACTED LIMEROCK BASE.
4. TEMPORARY SIDEWALK TO COMPLY WITH ALL ADA STANDARDS INCLUDING SLOPES AND TRIPPING HAZARDS.



MARTIN COUNTY PUBLIC WORKS - STANDARD DETAILS

STABILIZED CONSTRUCTION ENTRANCE

DETAIL

R-39

DATE: 04/23/19

TYPE "F" CURB & GUTTER
(PER FDOT STANDARD INDEX NO. 300)

6' MIN.
TRANSITION

VALLEY GUTTER

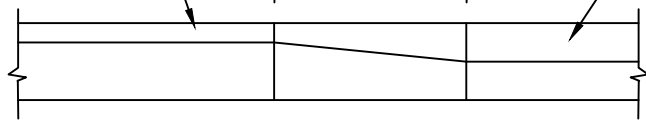

CURB TRANSITION – PLAN VIEW
N.T.S.

6' MIN.
TRANSITION

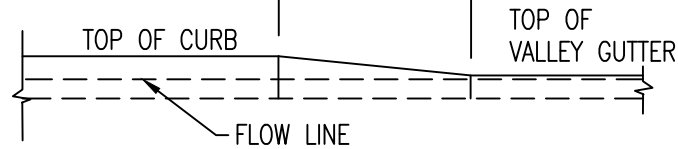

CURB TRANSITION – ELEVATION VIEW
N.T.S.

RIM ELEVATION
TOP OF VALLEY GUTTER
(EDGE OF PAVEMENT,
AS SHOWN ON PLANS)

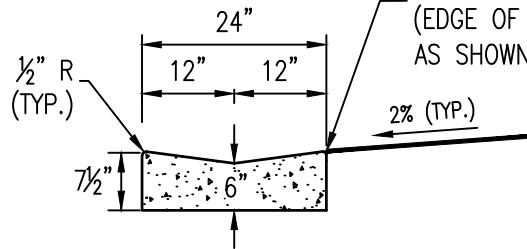

VALLEY GUTTER
N.T.S.

NOTES:

1. FDOT TYPE "D" CURB SHALL NOT BE ACCEPTABLE FOR THE OUTSIDE OF A TRAVEL LANE.
2. ALL CURB, CURB AND GUTTER MATERIALS AND CONSTRUCTION NOT SHOWN HEREIN SHALL BE IN ACCORDANCE WITH APPLICABLE FDOT STANDARD SPECIFICATIONS 520 AND FDOT STANDARD PLANS INDEX 520-001.
3. A DESIRED 8 FEET SHALL BE MAINTAINED BETWEEN EDGE OF TRAVEL LANE AND SIDEWALK WHERE CURB AND GUTTER DOES NOT EXIST (MINIMUM SHALL BE 4.5 FEET, UNLESS OTHERWISE APPROVED BY THE COUNTY ENGINEER).



MARTIN COUNTY PUBLIC WORKS - STANDARD DETAILS

CURB & GUTTER

DETAIL

R-40

DATE: 04/23/19

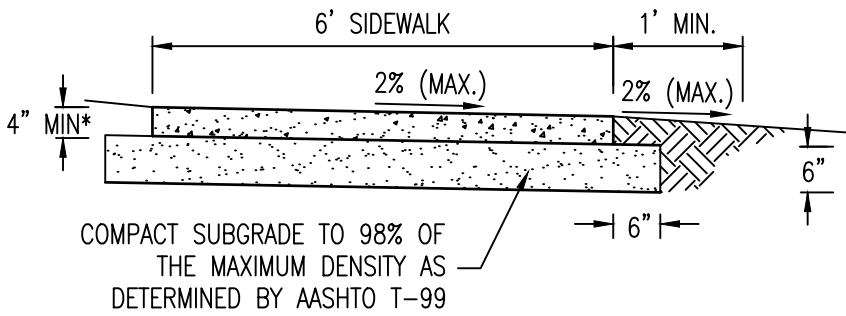

COMPACT SUBGRADE TO 98% OF THE MAXIMUM DENSITY AS DETERMINED BY AASHTO T-99

*SIDEWALKS THROUGH DRIVEWAYS SHALL BE 6" THICK

TYPICAL SIDEWALK
N.T.S.

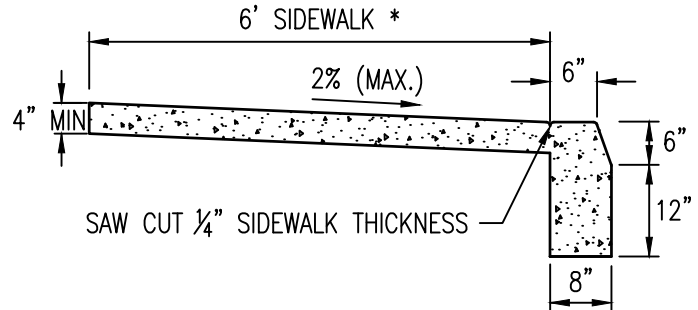

NOTE: FOR USE IN PARKING LOTS ONLY. SEE NOTE 1 ON MARTIN COUNTY PUBLIC WORKS STANDARD DETAILS R-40

TYPE "D" CURB & SIDEWALK COMBINATION
N.T.S.

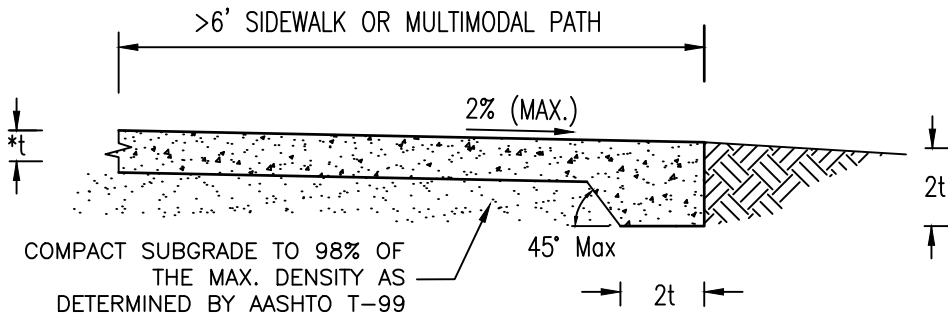

COMPACT SUBGRADE TO 98% OF THE MAX. DENSITY AS DETERMINED BY AASHTO T-99

*t IS TYPICALLY 4" - 6" AND SHALL BE SPECIFIED BY ENGINEER OF RECORD

TYPICAL MULTIMODAL PATHWAY or SIDEWALK > 6'
N.T.S.

NOTES:

1. SIDEWALK MATERIALS AND CONSTRUCTION SHOWN HEREIN SHALL BE IN ACCORDANCE WITH APPLICABLE FDOT STANDARD SPECIFICATIONS 522 AND FDOT STANDARD PLANS INDEX 522.
2. FIBER-REINFORCED CONCRETE FOR CURBS AND SIDEWALKS SHALL HAVE A MINIMUM COMPRESSIVE STRENGTH OF 3,000 PSI AT 28 DAYS WITH A WATER TO CEMENT RATIO NOT MORE THAN 0.53 (LB/LB).
3. THICKENED EDGE SHALL CONTAIN APPLICABLE SUBGRADE COMPACTED TO 98% OF MAXIMUM DRY DENSITY (AASHTO T-99)
4. A DESIRED 8 FEET SHALL BE MAINTAINED BETWEEN EDGE OF TRAVEL LANE AND SIDEWALK WHERE CURB AND GUTTER DOES NOT EXIST (MINIMUM SHALL BE 4.5 FEET, UNLESS OTHERWISE APPROVED BY THE COUNTY ENGINEER).



MARTIN COUNTY PUBLIC WORKS - STANDARD DETAILS

SIDEWALK

DETAIL

R-41

DATE: 04/23/19

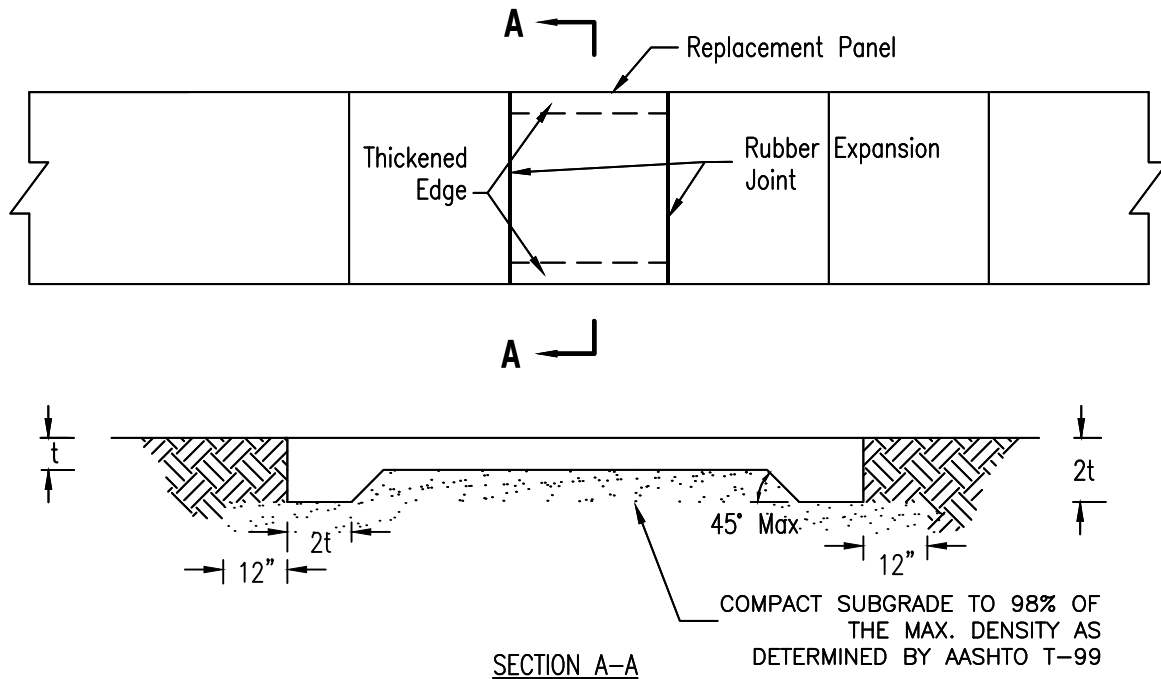

PROCEDURES FOR SIDEWALK PLACEMENT & REPAIR:

1. REMOVE EXISTING SIDEWALK TO THE FULL WIDTH FROM CONTROL JOINT TO CONTROL JOINT (I.E. ONE "SECTION")
2. COMPLETELY REMOVE ANY STRUCTURE, POLE OR DEVICE LOCATED WITHIN SECTION TO BE REPLACED.
3. BACKFILL ANY VOID CREATED OR CAUSED BY REMOVAL OF SUCH STRUCTURE, POLE OR DEVICE AND COMPACT TO 98% OF AASHTO T-99.
4. COMPACT SOIL UNDER PROPOSED SIDEWALK AND 12" BEYOND EACH SIDE OF SIDEWALK (WHEN RIGHT-OF-WAY ALLOWS) TO 98% OF AASHTO T-99
5. CONCRETE PREP AERATION AND PLACEMENT:
 - a) INSTALL EXPANSION JOINT AT ALL COLD JOINTS FLUSH WITH THE SURFACE OF THE SIDEWALK
 - 1) EXPANSION JOINT MATERIAL SHALL MEET THE AASHTO M153 STANDARD FOR TYPE IV: POLYURETHANE-BONDED RECYCLED RUBBER. FIBER EXPANSION JOINT MATERIAL SHALL NOT BE UTILIZED.
 - b) INSTALL 4" MINIMUM THICKNESS SIDEWALK OR MATCH EXISTING THICKNESS IF GREATER THAN 4".
 - 1) MIN. 3,000 PSI
 - 2) CONCRETE LOAD TICKETS SHOULD BE KEPT FOR FINAL INSPECTION AND SIGN-OFF
 - c) SCREED THE CONCRETE PERPENDICULAR TO THE FORMS TO OBTAIN THE REQUIRED GRADE AND REMOVE SURPLUS WATER AND LAITANCE.
 - d) FINISH WITH A BROOM AND ENSURE THAT THE SURFACE VARIATIONS ARE NOT MORE THAN $\frac{1}{4}$ " UNDER A 10-FOOT STRAIGHTEDGE, OR MORE THAN $\frac{1}{8}$ " ON A 5 FOOT TRANSVERSE SECTION. FINISH THE EDGE OF THE SIDEWALK WITH AN EDGING TOOL HAVING A RADIUS OF $\frac{1}{2}$ ".
6. REPAIR ALL RUTS AND/OR SOD THAT HAS BEEN DAMAGED. REGRADE WORK AREA AND PLACE NEW SOD IN ALL DISTURBED AREAS.
7. PEDESTRIAN SAFETY: ENSURE A PEDESTRIAN PATH IS SAFELY MAINTAINED IN ACCORDANCE WITH FDOT STANDARD PLAN INDEX 102-660.

NOTE: ANY ADDITIONAL SECTION OF SIDEWALK THAT ABUTS THE WORK AREA AND IS DEEMED UNSAFE BY THE COUNTY ENGINEER, SHALL BE REPLACED.



MARTIN COUNTY PUBLIC WORKS - STANDARD DETAILS

SIDEWALK REPLACEMENT / REPAIR

DETAIL

R-42

DATE: 04/23/19

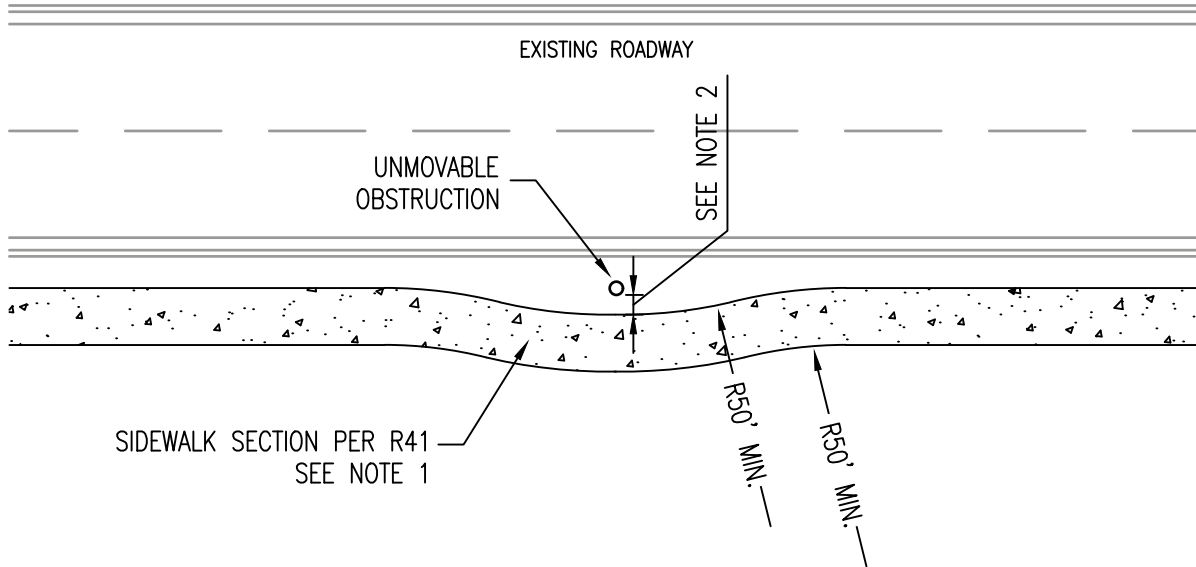

NOTES:

1. ALL SIDEWALK TRANSITIONS TO BE CURVILINEAR WITH A MINIMUM EDGE OF SIDEWALK RADIUS OF 50 FEET.
2. NO MINIMUM OFFSET REQUIRED FOR POWER POLE. MINIMUM OFFSET FOR FIRE HYDRANT OR OTHER OBSTRUCTION IS 1-FEET.



MARTIN COUNTY PUBLIC WORKS - STANDARD DETAILS

MEANDERING SIDEWALK

DETAIL

R-43

DATE: 04/23/19

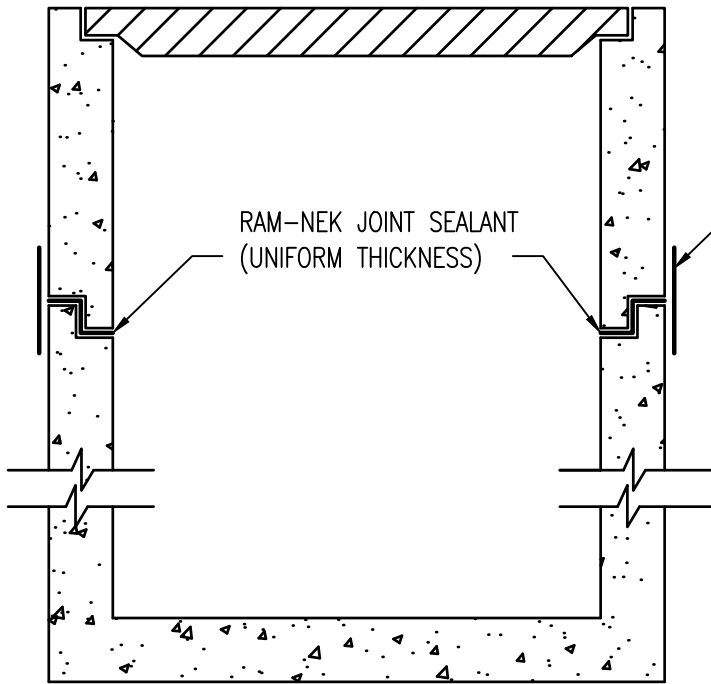

DRAINAGE INLET STRUCTURE
N.T.S.

WRAPIDSEAL EXTERIOR JOINT SEALANT
AROUND ENTIRE STRUCTURE (SEE NOTE #4)

INLET TYPE	CAST IRON	STEEL*
TYPE C	USF 6212	USF 6611
TYPE D	N/A	USF 6626
TYPE E	USF 6291	USF 6616
TYPE H	USF 6292	USF 6621

DRAINAGE INLET GRATE TYPES

*SEE NOTE #9

NOTES:

1. ALL INLET MATERIALS AND CONSTRUCTION NOT SHOWN HEREIN SHALL BE IN ACCORDANCE WITH FDOT STANDARD SPECIFICATION 425 AND FDOT STANDARD PLANS INDEX SERIES 425.
2. USE OF FDOT TYPE "9" CURB INLETS AND VALLEY GUTTER INLETS SHALL ONLY BE ACCEPTABLE ON LOCAL ROADWAYS AND WITHIN PARKING AREAS.
3. USE OF FDOT TYPE "10" CURB INLETS IS NOT ACCEPTABLE AT ANY LOCATION UNLESS APPROVED BY COUNTY ENGINEER.
4. INLET SHALL BE 1-PIECE MONOLITHIC. INLETS THAT REQUIRE TWO PIECES AS REQUIRED BY LOAD CONSTRAINTS ARE TO CONTAIN SEALED KEY WAYS WITH RAM-NEK ASPHALTIC SEALANT AND EXTERIOR JOINT SEALANT WITH WRAPIDSEAL OR APPROVED EQUIVALENT. ANY PROPOSED 2-PIECE STRUCTURE SHALL BE APPROVED BY THE COUNTY ENGINEER.
5. ALL INLETS SHALL HAVE A MINIMUM SUMP OF 18", UNLESS OTHERWISE APPROVED BY THE COUNTY ENGINEER.
6. DITCH BOTTOM INLETS SHALL NOT HAVE A SEPARATED TOP SLAB UNLESS OTHERWISE APPROVED BY THE COUNTY ENGINEER.
7. ALL INLETS SHALL BE PLACED OVER DRY, FIRM AND UNYIELDING MATERIAL OR IN ACCORDANCE WITH STANDARD DETAIL R-31A TYPICAL TRENCH DETAIL.
8. DITCH BOTTOM INLETS SHALL HAVE ANGLE IRON IN THE GRATE RECESSES TO ACCOMMODATE H-20 LOADING.
9. ALL INLET GRATES SHALL BEAR TRAFFIC LOADS AND SHALL BE CAST IRON IF APPLICABLE, OTHERWISE INLET GRATES SHALL BE HOT-DIPPED GALVANIZED STEEL.



MARTIN COUNTY PUBLIC WORKS - STANDARD DETAILS

LOCAL ROAD INLET

DETAIL

R-50

DATE: 04/23/19

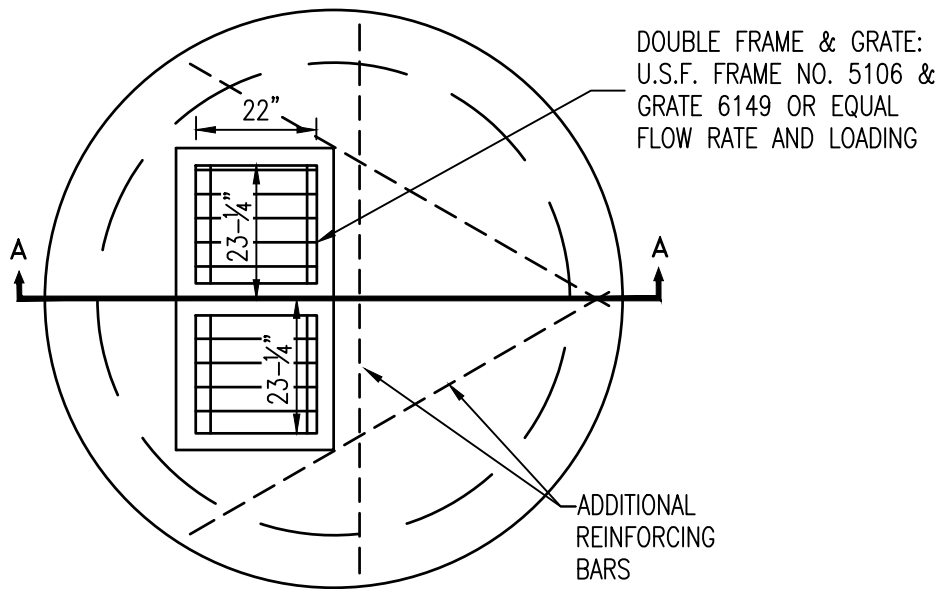

VALLEY GUTTER INLET DETAIL – PLAN VIEW

N.T.S.

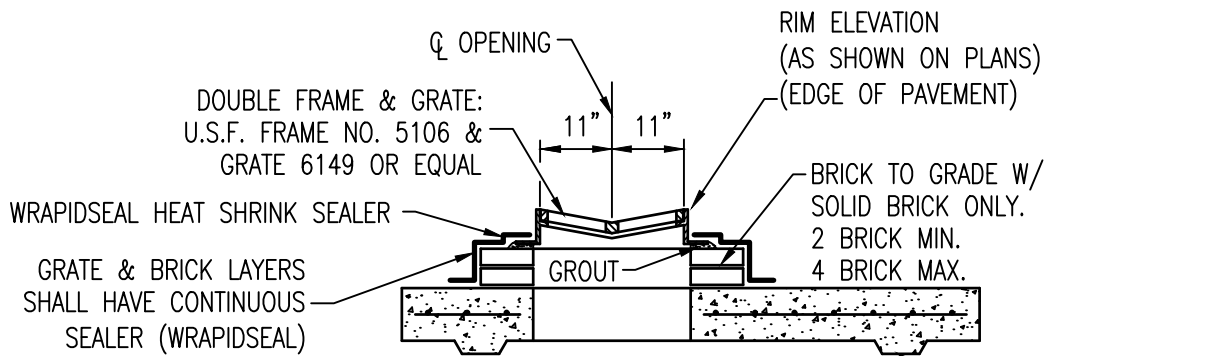

VALLEY GUTTER INLET DETAIL

SECTION A-A N.T.S.

VALLEY GUTTER INLETS:

1. ALL CONCRETE SHALL HAVE A MINIMUM COMPRESSIVE STRENGTH OF 4,000 PSI AT 28 DAYS.
2. KEY CUT IS REQUIRED WITH PRECAST TOPS ONLY. IF TOP SLAB IS CAST IN PLACE WITHOUT KEYWAY, 12" LONG NO. 4 REBAR DOWELS SHALL BE DRILLED AND EXPOXIED AT 12" O.C. TO SECURE TOP SLAB TO SIDE WALLS.
3. CENTERLINE OF OPENING SHALL BE OFFSET FROM CENTERLINE OF STRUCTURE.
4. GRATE & MANHOLE RINGS SHALL BE GROUTED IN PLACE.
5. GRATE & MANHOLE SEAT, GROUT, BRICKS, AND STRUCTURE SHALL BE CONTINUOUSLY ENCAPSULATED WITH WRAPIDSEAL JOINT SEALER



MARTIN COUNTY PUBLIC WORKS - STANDARD DETAILS

VALLEY GUTTER INLET

DETAIL

R-51

DATE: 04/23/19

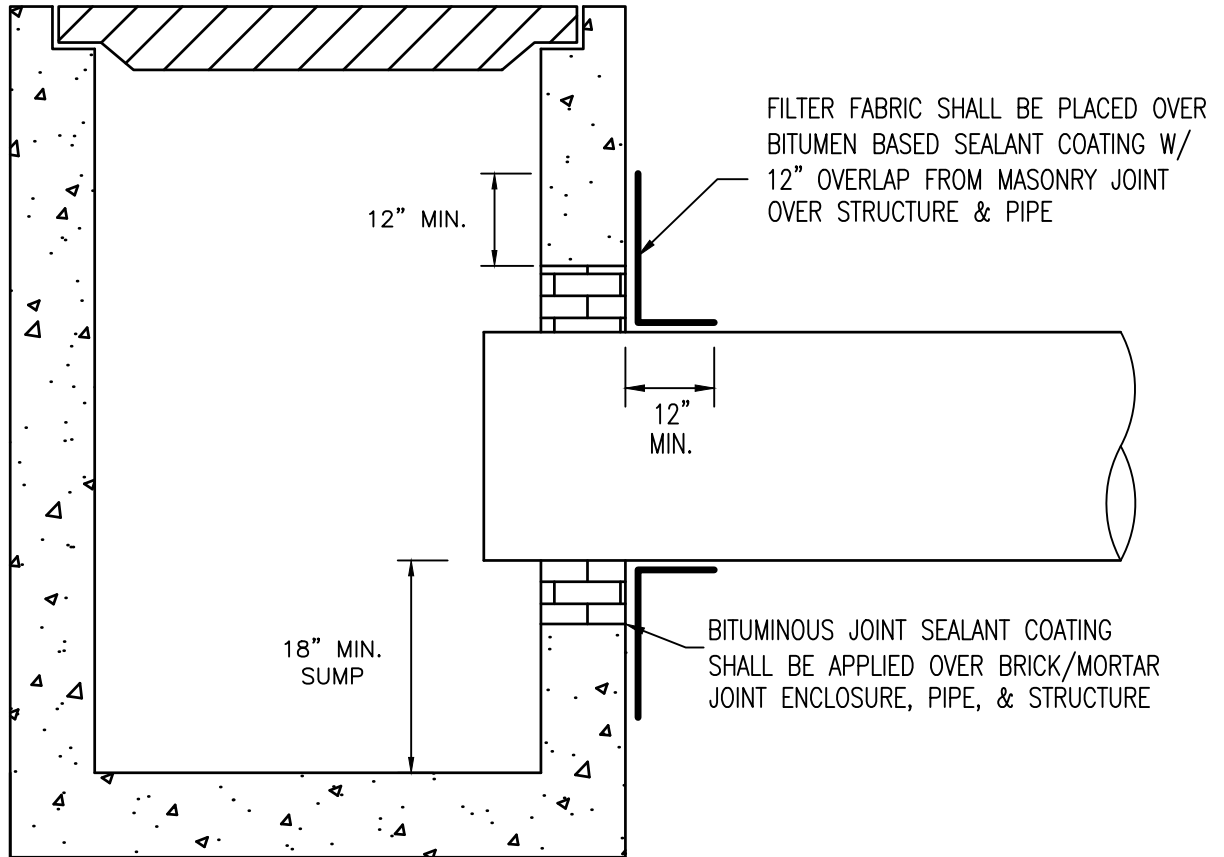

NOTES:

1. ALL INLET MATERIALS AND CONSTRUCTION NOT SHOWN HEREIN SHALL BE IN ACCORDANCE WITH FDOT STANDARD SPECIFICATION 425 AND FDOT STANDARD PLANS INDEX SERIES 425.
2. DRAINAGE STRUCTURE-PIPE CONNECTION MASONRY JOINT SHALL BE FILLED WITH MIXTURE OF APPROVED BRICK AND TYPE I AND/OR II CONCRETE MORTAR.
3. ALL MASONRY JOINT SEAL BRICK OR WALL MATERIAL UNIT SHALL BE SATURATED BEFORE GROUT SEALING.
4. ALL MASONRY JOINT CONCRETE MORTAR SHALL BE TYPE I AND/OR II PREMIXED SILICA SAND-PORTLAND CEMENT (3:1 MAX). NO MIXING OF SAND-CEMENT IS PERMITTED ON SITE UNLESS APPROVED BY THE COUNTY ENGINEER.



MARTIN COUNTY PUBLIC WORKS - STANDARD DETAILS

PIPE - STRUCTURE CONNECTION

DETAIL

R-60

DATE: 04/23/19

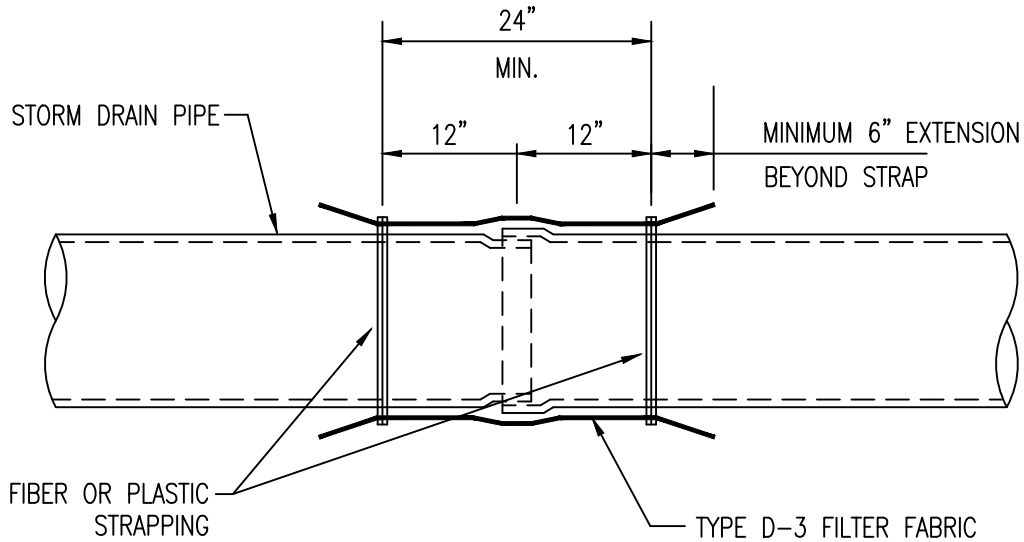

NOTES:

1. ALL PIPE LOCATED UNDER ROADWAYS AND/OR RESIDENTIAL PARKING AREAS SHALL BE REINFORCED CONCRETE PIPE (RCP).
2. MINIMUM PIPE DIAMETER SHALL BE 15" OR ELLIPTICAL EQUIVALENT.
3. FILTER FABRIC SHALL BE OVERLAPPED 2'-0" MINIMUM AT ALL JOINTS, INCLUDING ALL END TREATMENTS, REGARDLESS OF PIPE CULVERT MATERIAL.
4. A CONTINUOUS PIECE OF FILTER FABRIC, CONFORMING TO TYPE "D-3" OF FDOT STANDARD SPECIFICATIONS 985, SHALL BE USED AT ALL JOINTS, INCLUDING STRUCTURES AND END TREATMENTS.



MARTIN COUNTY PUBLIC WORKS - STANDARD DETAILS

STORM DRAIN PIPE AND PIPE JOINT

DETAIL

R-70

DATE: 04/23/19

CONCRETE TURFBLOCK

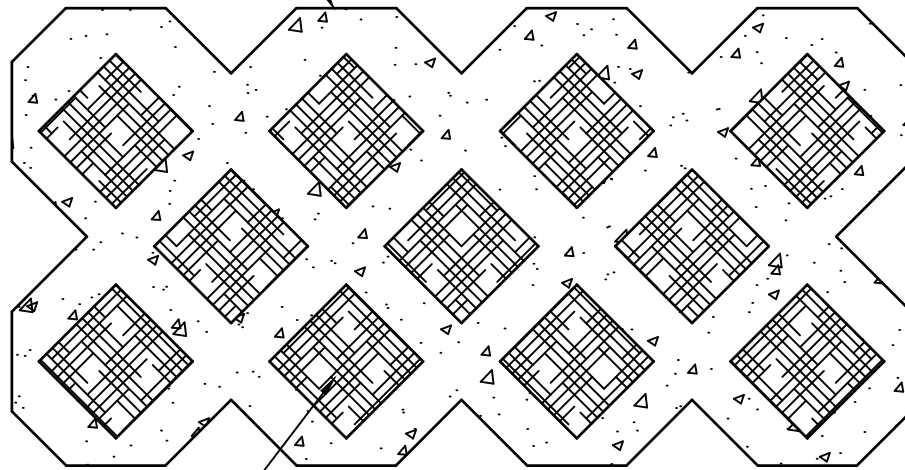

FILL VOID SPACE WITH SAND
& BAHIA/RYE MIX

PLAN VIEW

N.T.S.

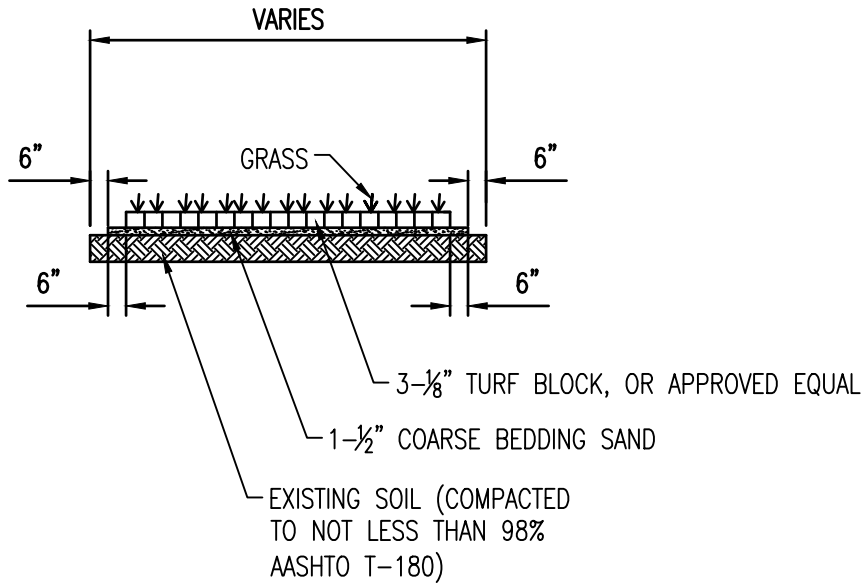

NOTE: TURF BLOCK MAY BE USED
IN OVERFLOW PARKING OR FOR
EMERGENCY ACCESS AREAS

SECTION VIEW

N.T.S.



MARTIN COUNTY PUBLIC WORKS - STANDARD DETAILS

TURF BLOCK

DETAIL

R-80

DATE: 04/23/19

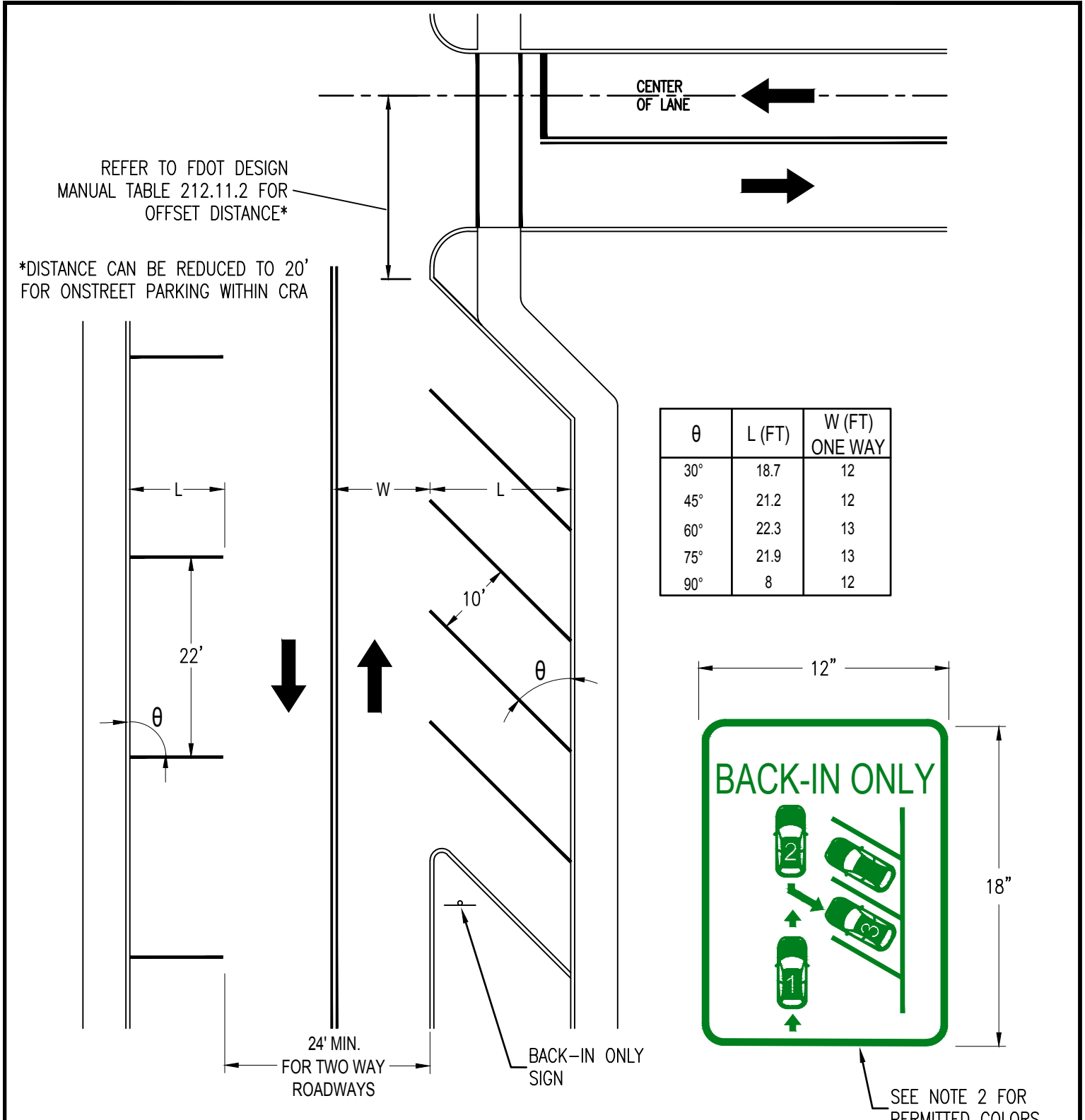

NOTE:

1. BACK-OUT PARKING UTILIZING THE PUBLIC RIGHT-OF-WAY AS AN ACCESS AISLE IS PROHIBITED EXCEPT WHEN APPLIED TO SINGLE-FAMILY AND DUPLEX LAND USES OR ON A STREET WHERE THE POSTED SPEED LIMIT IS 30 MPH OR LESS.
2. BACK-IN ONLY SIGN SHALL CONSIST OF A GREEN LEGEND AND BORDER ON A WHITE BACKGROUND.



MARTIN COUNTY PUBLIC WORKS - STANDARD DETAILS

BACK-IN PARKING

DETAIL

R-81

DATE: 04/23/19

60' R. TYP.
(see note 1)

50' R (MIN.)

CURBING
SEE NOTE 3

OPTIONAL ISLAND
SEE NOTE 2

25' R

35' R

10'

10'

50' MIN. RIGHT-OF-WAY

60' MIN. RIGHT-OF-WAY
FOR SWALE DRAINAGE

NOTE:

1. RIGHT-OF-WAY MINIMUM RADIUS FOR ROADS WITH SWALE DRAINAGE IS 70 FEET.
2. FOR CUL-DE-SACS WITH A CENTRAL ISLAND CONFIGURATION, A MINIMUM RADIUS OF 18 FEET TO THE FACE OF CURB IS REQUIRED.
3. IF ROADWAY UTILIZES CURB AND GUTTER DRAINAGE SYSTEM, CURB MINIMUM PROFILE SLOPE OF CURB SHALL BE 0.3%.



MARTIN COUNTY PUBLIC WORKS - STANDARD DETAILS

ROAD END TREATMENT (CUL-DE-SAC)

DETAIL

R-90A

DATE: 04/23/19

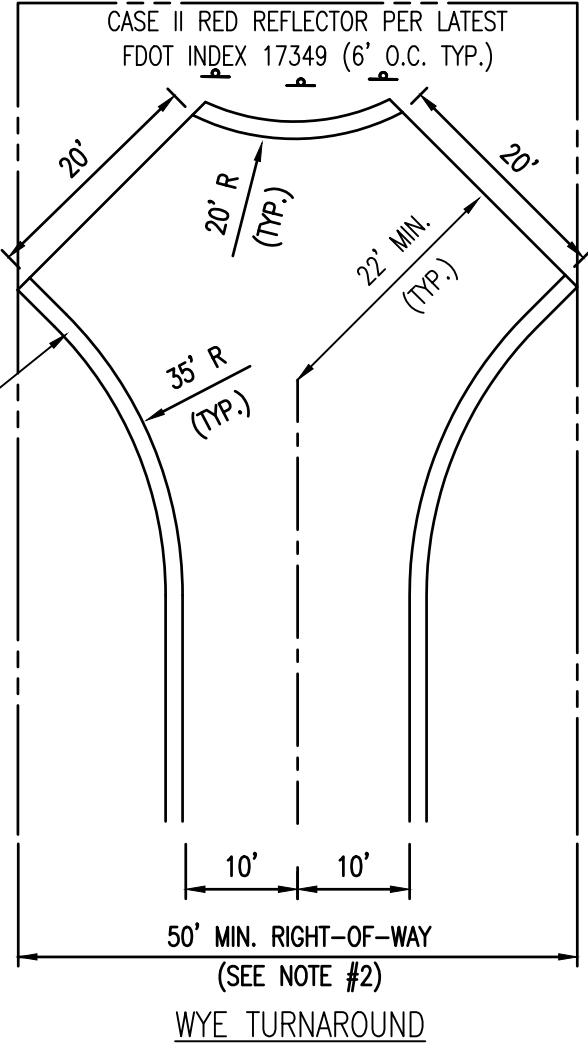
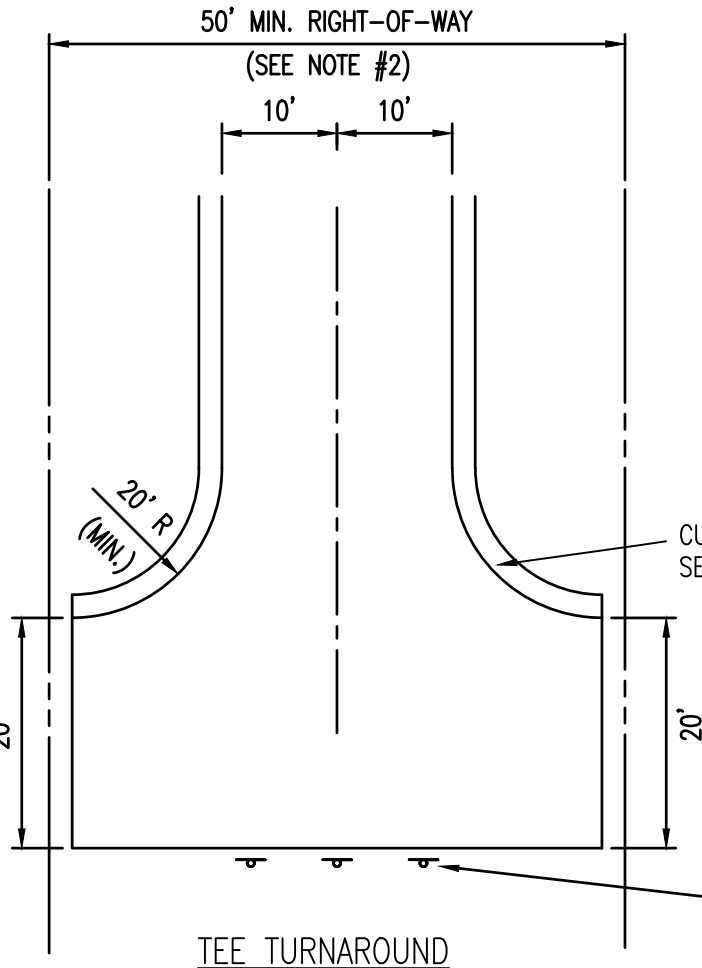

NOTE:

1. MARTIN COUNTY STANDARD PAVEMENT SECTION SHALL BE UTILIZED.
2. 60 FOOT MINIMUM RIGHT-OF-WAY REQUIRED FOR SWALE DRAINAGE.
3. THESE TYPES OF TURNAROUNDS SHALL ONLY BE USED FOR ROADWAYS LESS THAN 150' LONG AND ARE NOT INTENDED FOR FIRE ACCESS MANEUVERING.
4. IF ROADWAY UTILIZES CURB AND GUTTER DRAINAGE SYSTEM, CURB MINIMUM PROFILE SLOPE OF CURB SHALL BE 0.3%.



MARTIN COUNTY PUBLIC WORKS - STANDARD DETAILS

ROAD END TREATMENT (TURNAROUNDS)

DETAIL

R-90B

DATE: 04/23/19

MITERED END SECTION PER DETAIL R-35 OR HEADWALL PER FDOT SPECIFICATIONS OR COUNTY ENGINEER APPROVED EQUAL

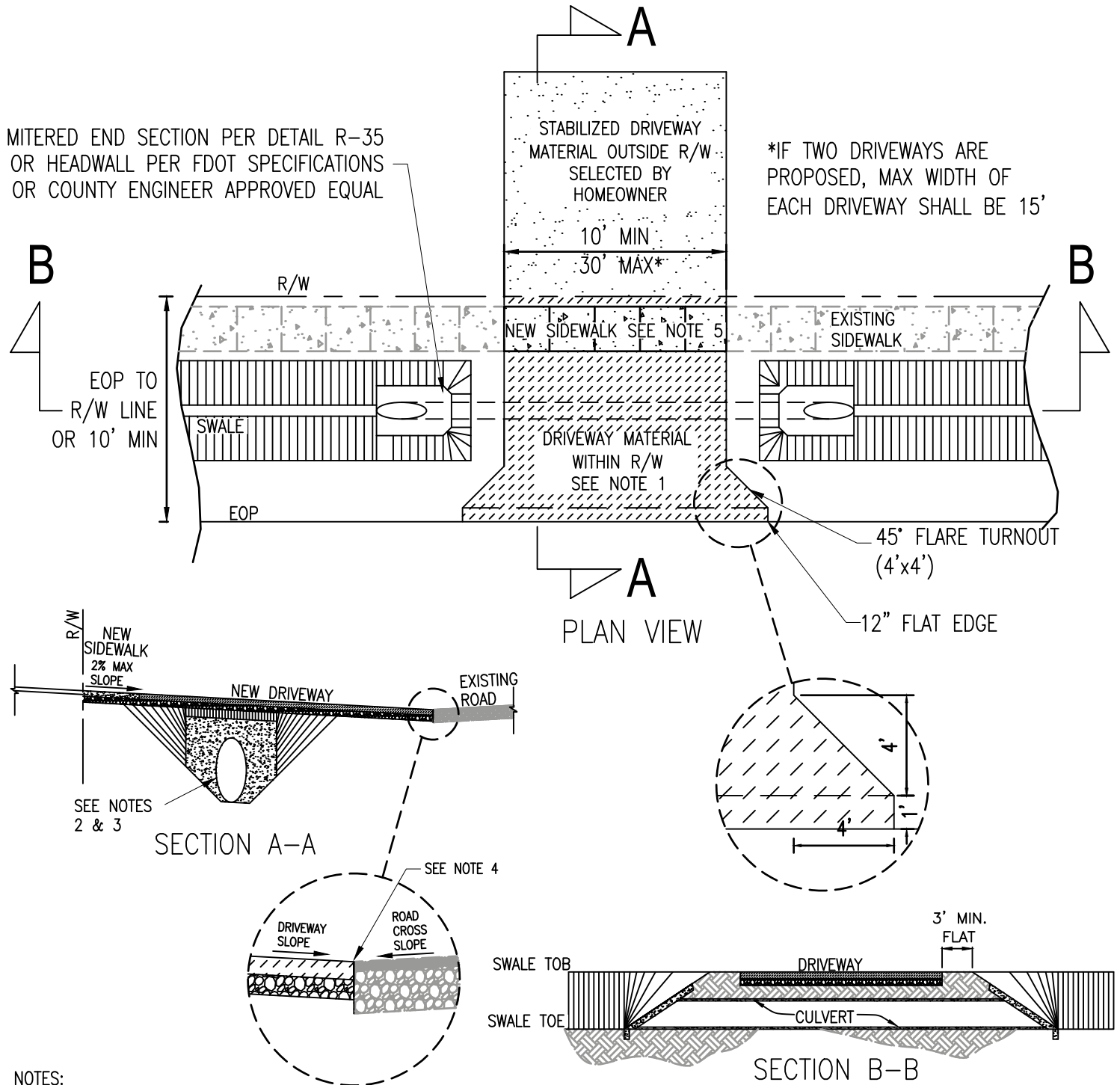

NOTES:

1. THE PORTION OF DRIVEWAY WITHIN THE RIGHT-OF-WAY SHALL BE 6" THICK 3000 PSI CONCRETE, 1" THICK ASPHALT CONCRETE WITH A BASE COURSE, OR PAVER BRICKS WITH A BASE COURSE. BASE COURSE PER FDOT BASE GROUP 4 AS SHOWN IN FDOT FLEXIBLE PAVEMENT DESIGN MANUAL TABLE 5.6. OTHER HARDENED MATERIALS MUST BE APPROVED BY THE COUNTY ENGINEER.
2. CULVERT INVERTS SHALL MATCH THE DRAINAGE CONVEYANCE FLOW LINE OF UPSTREAM AND DOWNSTREAM CULVERT INVERTS.
3. CULVERT SIZE SHALL BE EQUIVALENT OR GREATER THAN UPSTREAM CULVERT OR MIN. OF 15" DIA. OR 12"x18" ELLIPTICAL.
4. THE GRADE DIFFERENCE BETWEEN DRIVEWAY SLOPE AND ROAD CROSS SLOPE SHALL COMPLY WITH THE GUIDELINES FOUND IN TABLE 4.19.10 OF SECTION 4.845 OF DIVISION 19 - ROADWAY DESIGN OF THE MARTIN COUNTY LAND DEVELOPMENT REGULATIONS.
5. SAWCUT AND REMOVE EXISTING 4" SIDEWALK WITHIN DRIVEWAY FOOTPRINT. INSTALL NEW 6" CONCRETE SIDEWALK PER DETAIL R-41.



MARTIN COUNTY PUBLIC WORKS - STANDARD DETAILS

RESIDENTIAL DRIVEWAY - CULVERT

DETAIL

R-91A

DATE: 04/23/19

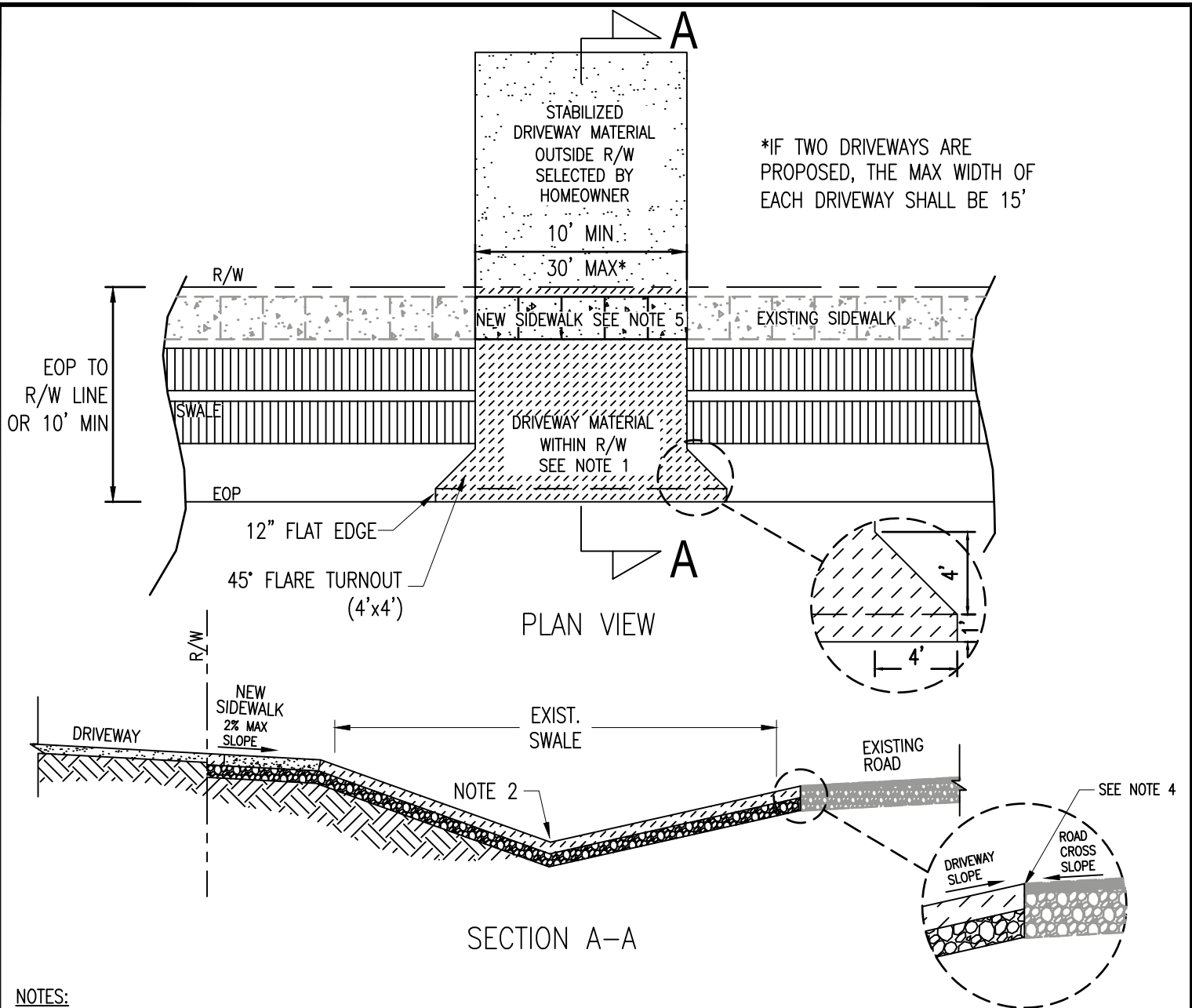

NOTES:

1. THE PORTION OF DRIVEWAY WITHIN THE RIGHT-OF-WAY SHALL BE 6" THICK 3000 PSI CONCRETE, 1" THICK ASPHALT CONCRETE WITH A BASE COURSE, OR PAVER BRICKS WITH A BASE COURSE. BASE COURSE PER FDOT BASE GROUP 4 AS SHOWN IN FDOT FLEXIBLE PAVEMENT DESIGN MANUAL TABLE 5.6. OTHER HARDENED MATERIALS MUST BE APPROVED BY THE COUNTY ENGINEER.
2. DRIVEWAY INVERTS SHALL MATCH THE DRAINAGE CONVEYANCE FLOW LINE OF UPSTREAM AND DOWNSTREAM SWALES. IF ROADSIDE SWALES DO NOT EXIST, DRIVEWAY SHALL HAVE A 0.2' INVERT LOCATED 7- FEET FROM THE EDGE OF PAVEMENT. GRADING A NEW ROADSIDE SWALE ADJACENT TO PROPERTY FRONTAGE MAY BE APPROVED BY THE COUNTY ENGINEER FOR THE PURPOSE OF DIRECTING STORMWATER OFF THE DRIVEWAY .
3. GRADE CHANGES OF MORE THAN 14% SHALL MEET THE REQUIRED CREST/SAG TRANSITION LENGTH PER FDOT STANDARD PLANS INDEX 000-515. DESIGNS NOT ABLE TO MEET THE REQUIREMENTS OF FDOT STANDARD PLANS INDEX 000-515 SHALL REQUIRE APPROVAL OF THE COUNTY ENGINEER.
4. THE GRADE DIFFERENCE BETWEEN DRIVEWAY SLOPE AND ROAD CROSS SLOPE SHALL COMPLY WITH THE GUIDELINES FOUND IN TABLE 4.19.10 OF SECTION 4.845 OF DIVISION 19 - ROADWAY DESIGN OF THE MARTIN COUNTY LAND DEVELOPMENT REGULATIONS.
5. SAWCUT AND REMOVE EXISTING 4" SIDEWALK WITHIN DRIVEWAY FOOTPRINT. INSTALL NEW 6" CONCRETE SIDEWALK PER DETAIL R-41.



MARTIN COUNTY PUBLIC WORKS - STANDARD DETAILS

RESIDENTIAL DRIVEWAY - INVERTED

DETAIL

R-91B

DATE: 04/23/19

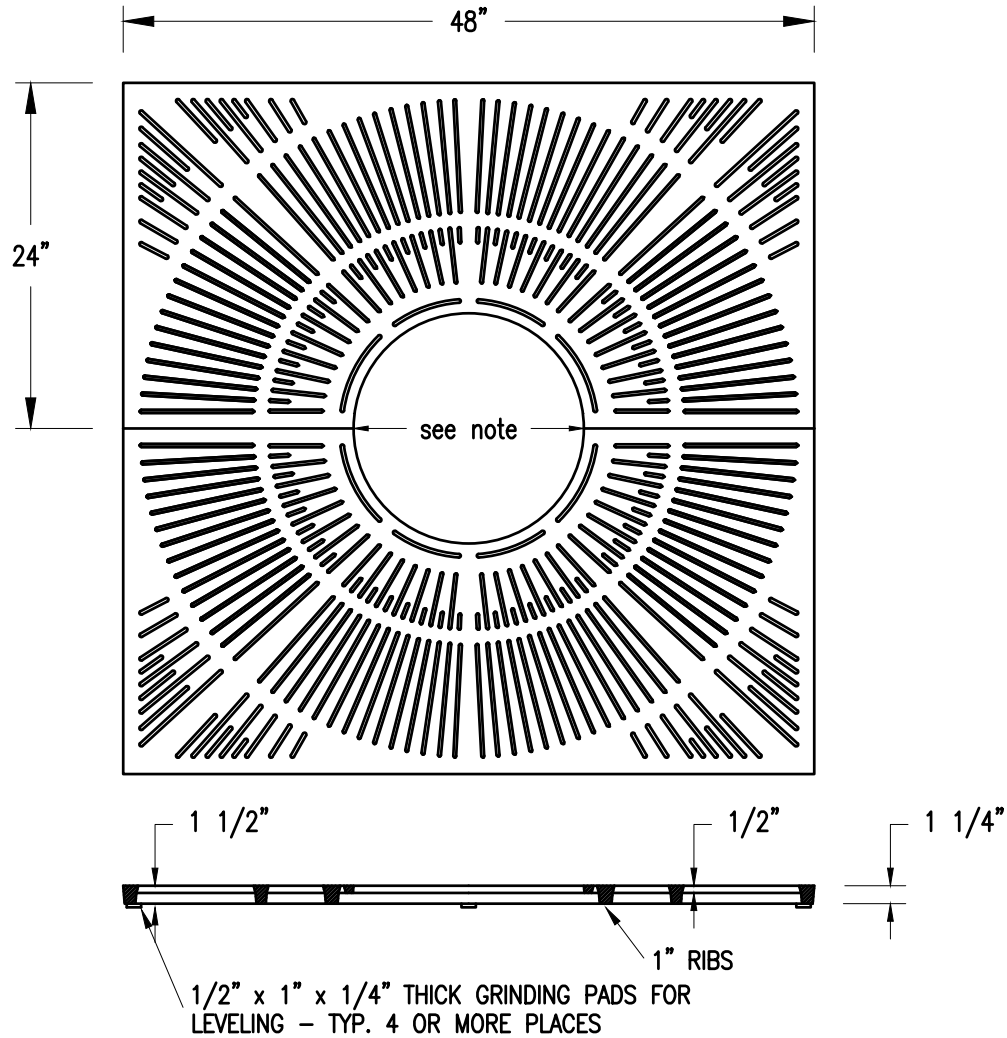

This drawing embodies a confidential proprietary design of IRONSMITH Palm Desert, CA. All design, manufacturing, reproduction, use, sale, and other rights regarding the same are expressly reserved. This drawing is submitted under confidential relationship for a specific purpose and the recipient agrees by accepting this drawing not to supply or disclose any information regarding it to any unauthorized person or to incorporate any special feature peculiar to this design in other projects. The information disclosed in this drawing may be covered completely or in part by patents pending. Designers may incorporate this drawing in their plans for the purpose of showing design intent. This drawing is not to be used for the purpose of product production.

NOTES:

1. TREE GRATE BY IRONSMITH, INC. OR APPROVED EQUIVALENT.
2. 48" X 48" TREE GRATE IN TWO SECTIONS.
3. 1/4" MAXIMUM SLOT OPENING FOR PEDESTRIAN SAFETY AND A.D.A. COMPLIANCE.
4. CAST FROM 100% RECYCLED IRON, ALUMINUM, OR BRONZE FOR PEDESTRIAN LOADS ONLY.
5. TREE OPENING 16", 18", OR 28" GRATES CAN BE ORDERED WITH OR LATER EXPANDED TO THESE OPENINGS.
6. FINISH: UNFINISHED OR BLACK DIP OR ENAMEL PAINT OR POLYURETHANE PAINT OR POWDER COAT.
7. FOR INSTALLATION USE FRAME MODEL M4800F. OUTER FRAME DIMENSION IS 3/4" ± 1/8" GREATER THAN GRATE.



MARTIN COUNTY PUBLIC WORKS - STANDARD DETAILS

TREE GRATE

DETAIL

R-100

DATE: 04/23/19

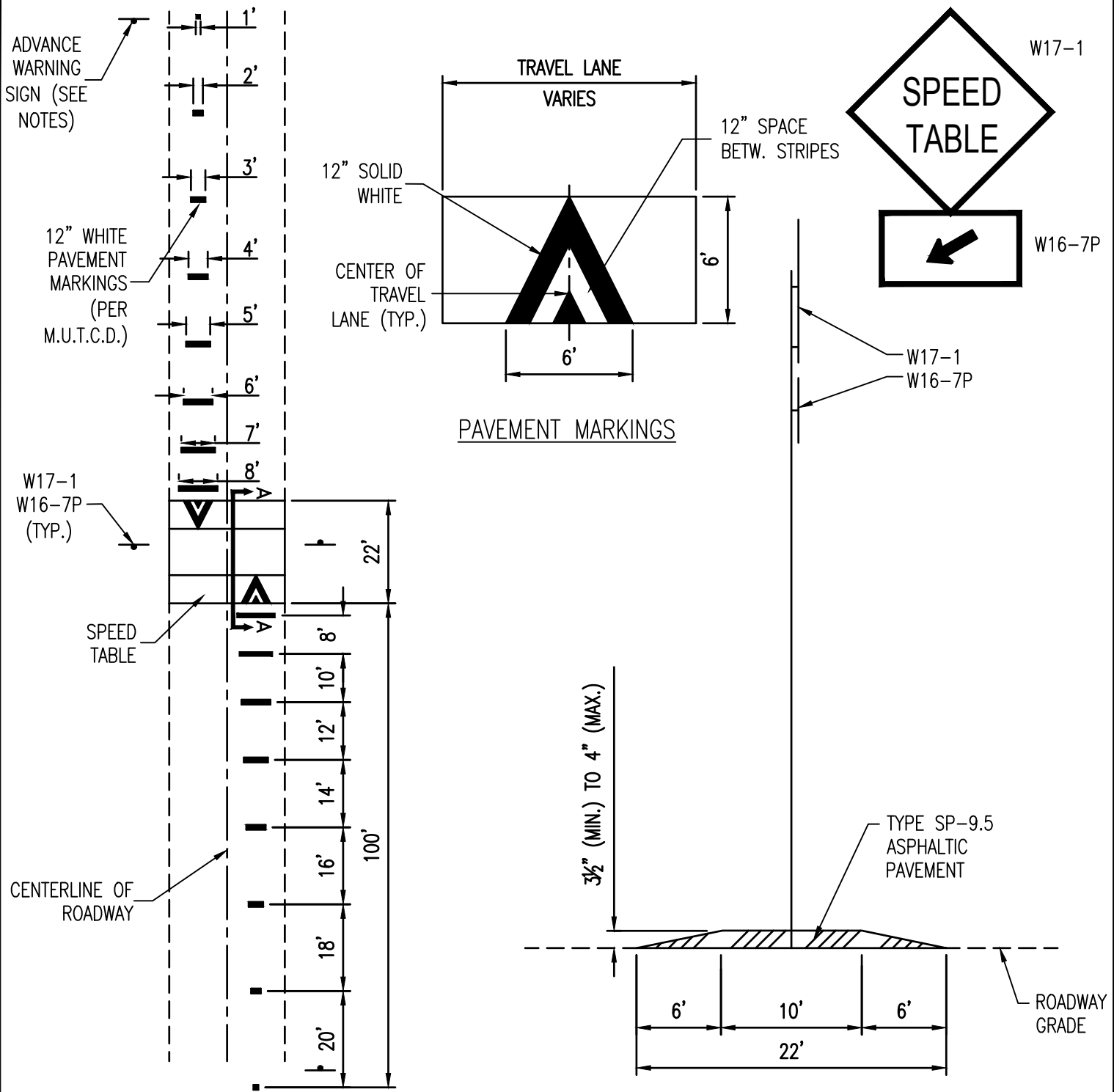

PLAN
N.T.S.

SECTION A-A
N.T.S.

NOTES:

1. ADVANCE WARNING SIGN DISTANCE SHALL BE IN ACCORDANCE WITH THE MANUAL ON UNIFORM TRAFFIC CONTROL DEVICES (MUTCD) REQUIREMENTS.
2. ALL PAVEMENT MARKINGS SHALL BE THERMOPLASTIC IN ACCORDANCE WITH SECTION 711 OF THE FDOT STANDARD SPECIFICATIONS AND PART 3 OF THE M.U.T.C.D.



MARTIN COUNTY PUBLIC WORKS - STANDARD DETAILS

TRAFFIC CALMING (SPEED TABLE)

DETAIL

R-110A

DATE: 04/23/19

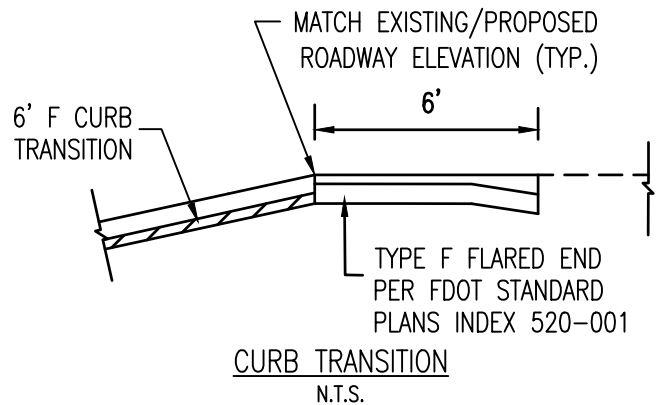
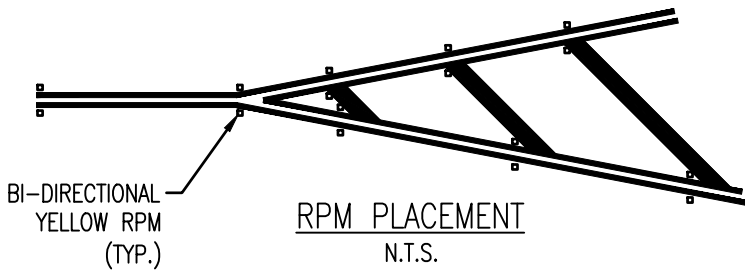
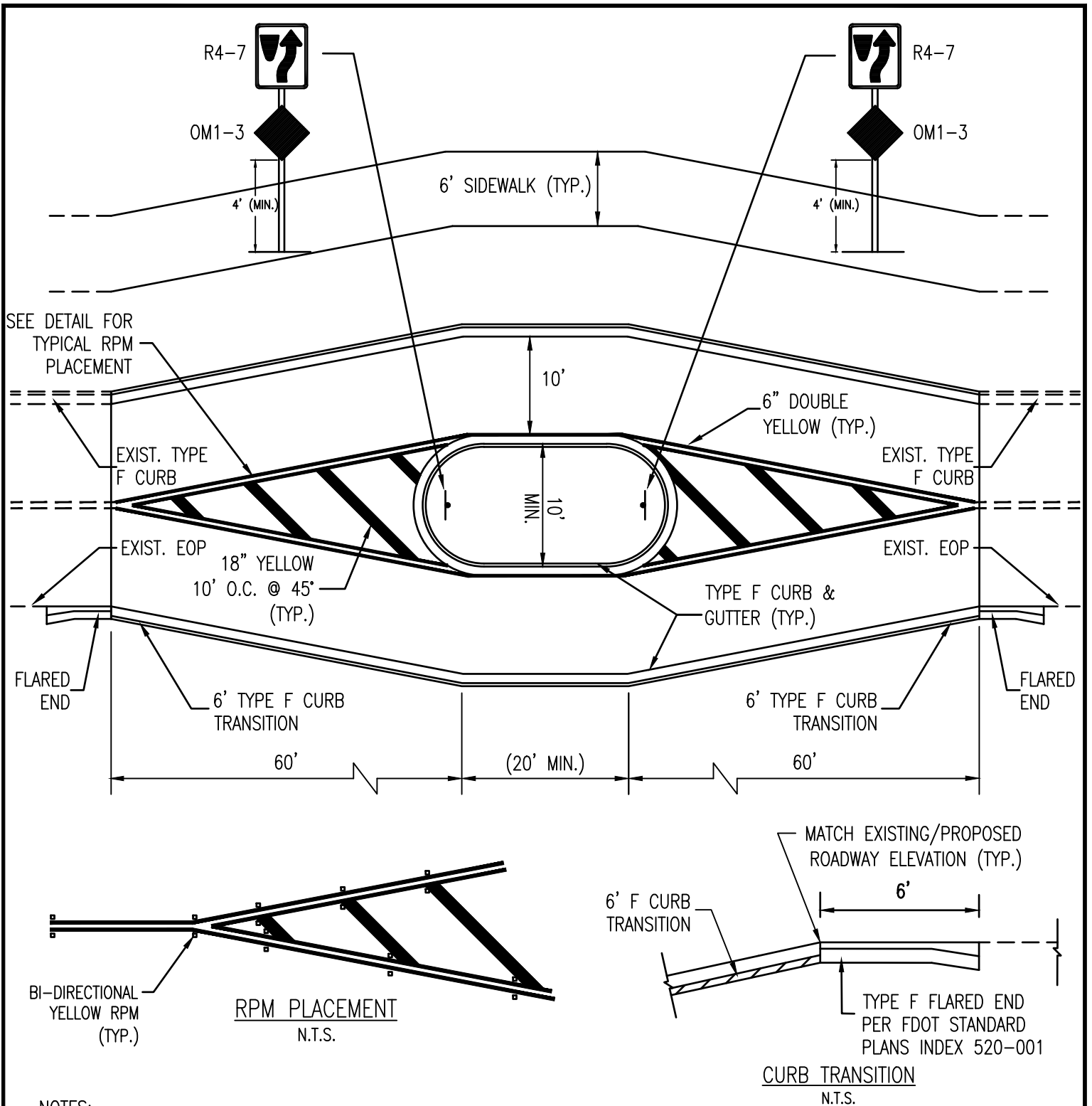

NOTES:

1. ALL PAVEMENT MARKINGS SHALL BE THERMOPLASTIC IN ACCORDANCE WITH SECTION 711 OF THE FDOT STANDARD SPECIFICATIONS.
2. TRAFFIC SEPARATION PAVEMENT MARKING LAYOUT SHALL BE IN ACCORDANCE WITH FDOT STANDARD INDEX 17346.
3. TRAFFIC SEPARATION RPM PLACEMENT SHALL BE IN ACCORDANCE WITH FDOT STANDARD INDEX 17352.
4. FDOT TYPE F CURB TRANSITION SHALL BE CONSTRUCTED MONOLITHICALLY.



MARTIN COUNTY PUBLIC WORKS - STANDARD DETAILS

TRAFFIC CALMING (SPLITTER ISLAND)

DETAIL

R-110B

DATE: 04/23/19

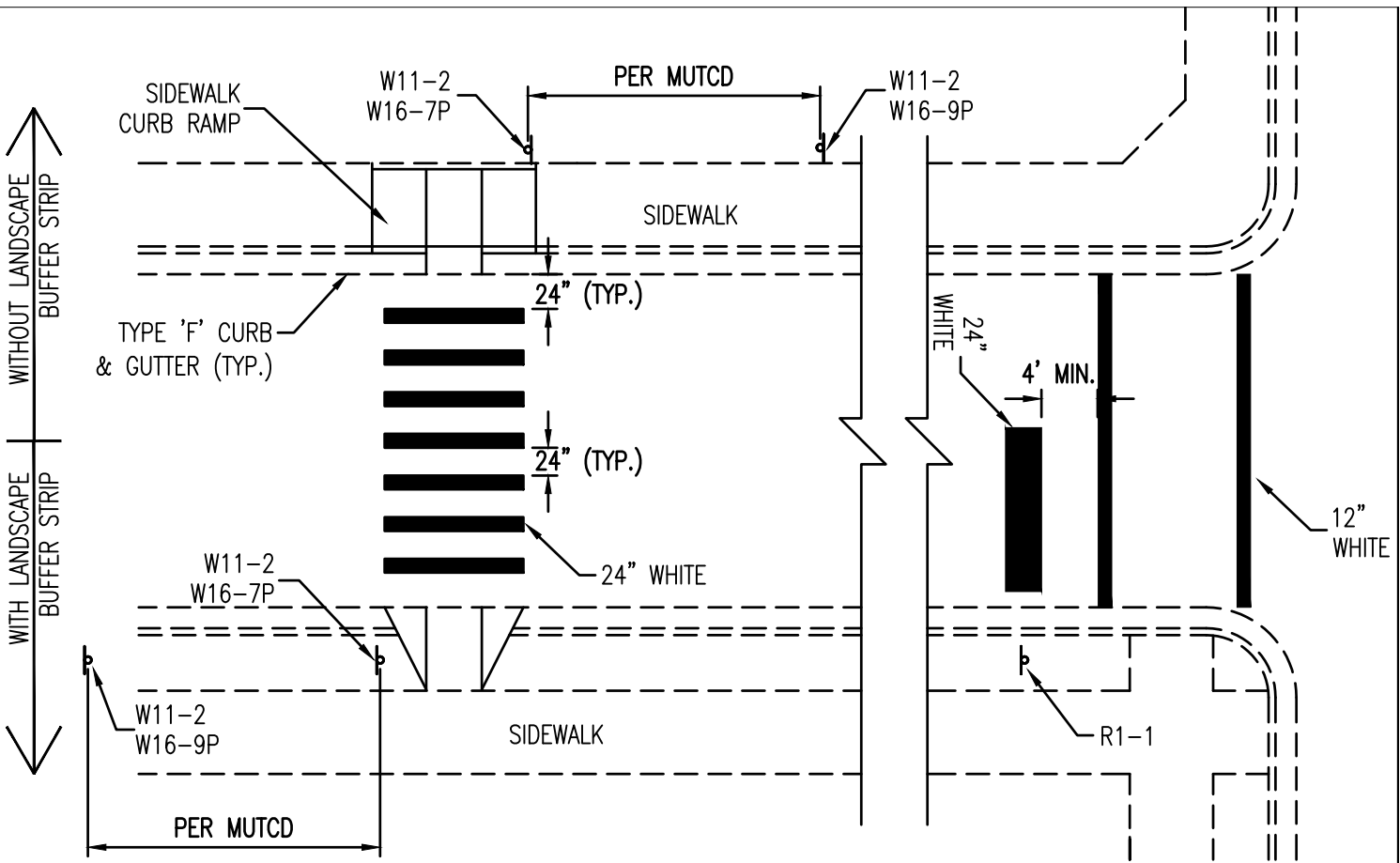

MID-BLOCK CROSSWALK

STOP-CONTROLLED CROSSWALK



W11-2



W16-7P



W16-9P



R1-1

SIGN DETAILS

NOTES:

1. ALL PAVEMENT MARKINGS SHALL BE THERMOPLASTIC IN ACCORDANCE WITH FDOT STANDARD SPECIFICATION 711.
2. MID-BLOCK CROSSWALK MARKINGS SHALL BE WHITE SPECIAL EMPHASIS.
3. STOP-CONTROLLED CROSSWALK MARKINGS SHALL BE STANDARD.
4. PUBLIC SIDEWALK CURB RAMPs AND DETECTABLE WARNING SURFACES SHALL BE DESIGNED IN ACCORDANCE WITH FDOT STANDARD PLANS INDEX 522. DETECTABLE WARNING SURFACES SHALL BE CAST IN PLACE ARMOR TILE OR APPROVED EQUAL AND BRICK RED IN COLOR. BOLT OR SCREW DOWN TYPES ARE PROHIBITED.
5. CROSSWALK WARNING SIGNAGE SHALL BE YELLOW, UNLESS CROSSWALK IS LOCATED IN A SCHOOL ZONE WHERE LIME-GREEN SHALL BE USED.
6. SIGN INSTALLATION SHALL BE PER TRAFFIC CONTROL DETAIL, R-140A.



MARTIN COUNTY PUBLIC WORKS - STANDARD DETAILS

CROSSWALK

DETAIL

R-120A

DATE: 04/23/19

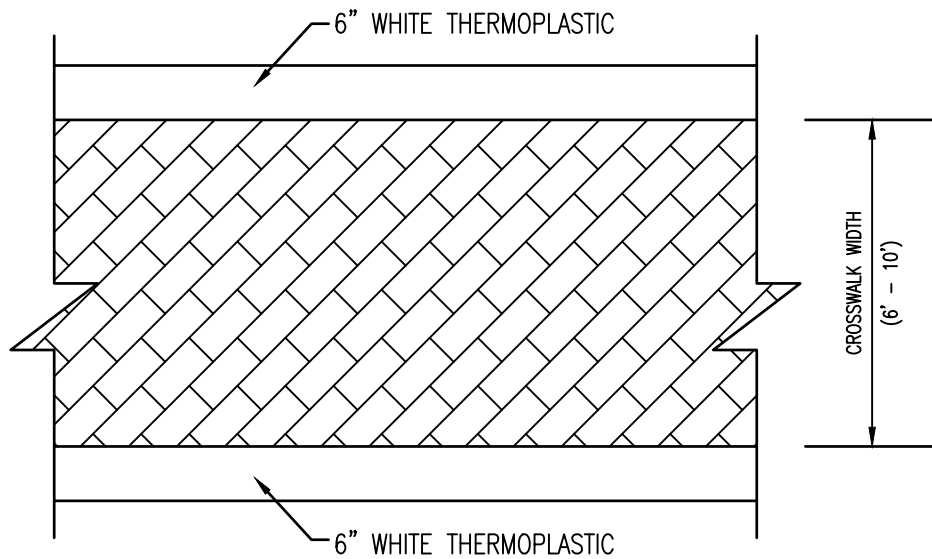
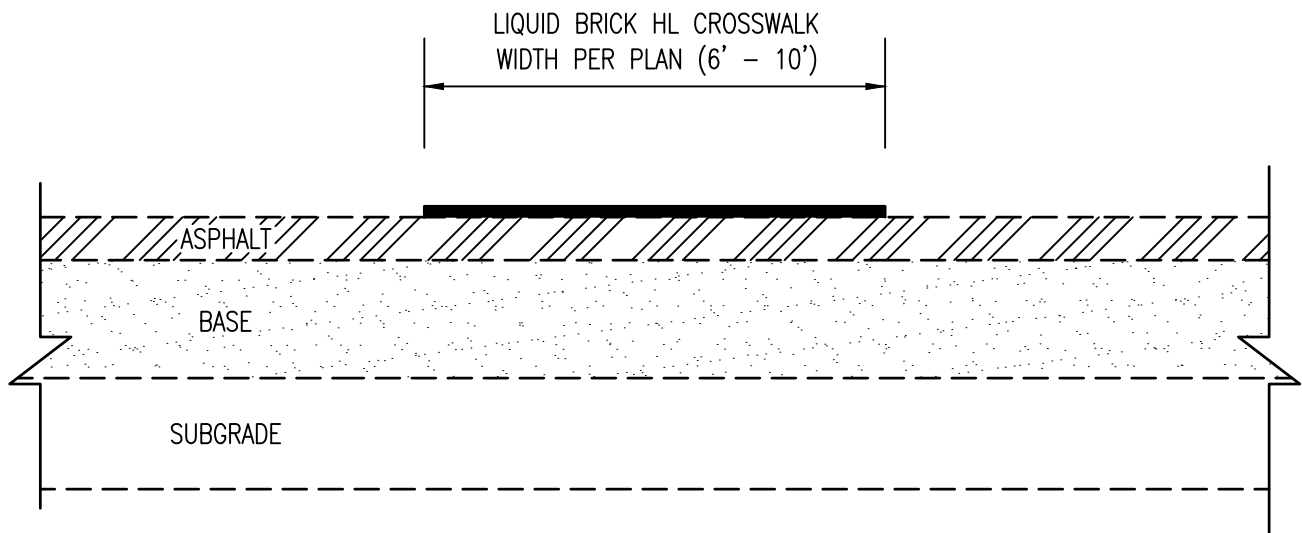

NOTES:

1. THE STAMPED APPLICATION SHALL BE AN FDOT APPROVED LIQUID BRICK- HF W/ NATURA COLORED AGGREGATE WITH A HIGH FRICTION SURFACING SYSTEM COMPRISED OF A THERMOSETTING MODIFIED EPOXY COMPOUND MANUFACTURED BY ATLANTIC PAVING COMPANY INC., OR APPROVED EQUAL.
2. CROSSWALK EPOXY-AGGREGATE COMPOUND MAT MUST HAVE PARALLEL 12" WHITE STRIPING ON BOTH SIDES OF PATTERN OR 12" WHITE THERMOPLASTIC ON ADJACENT ASPHALT.
3. SUBSTITUTION REQUESTS MUST BE SUBMITTED AND APPROVED BY COUNTY ENGINEER BEFORE APPLICATION.



MARTIN COUNTY PUBLIC WORKS - STANDARD DETAILS

CROSSWALK (STAMPED)

DETAIL

R-120B

DATE: 04/23/19

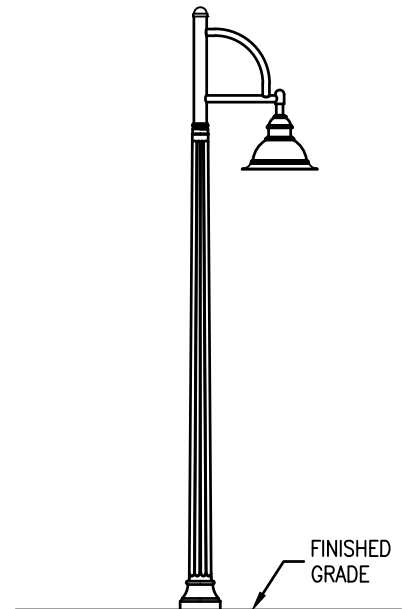
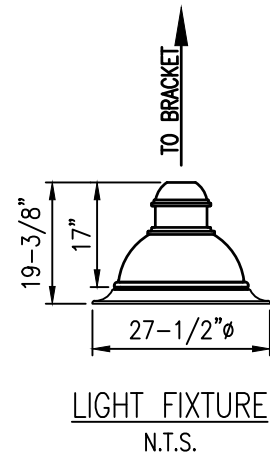
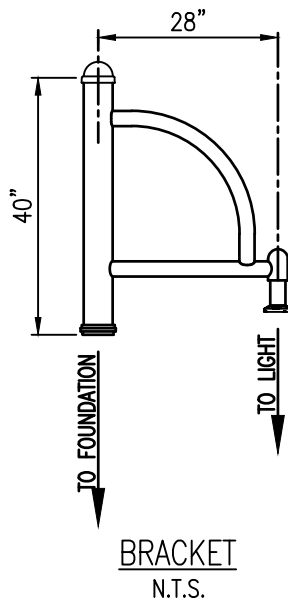
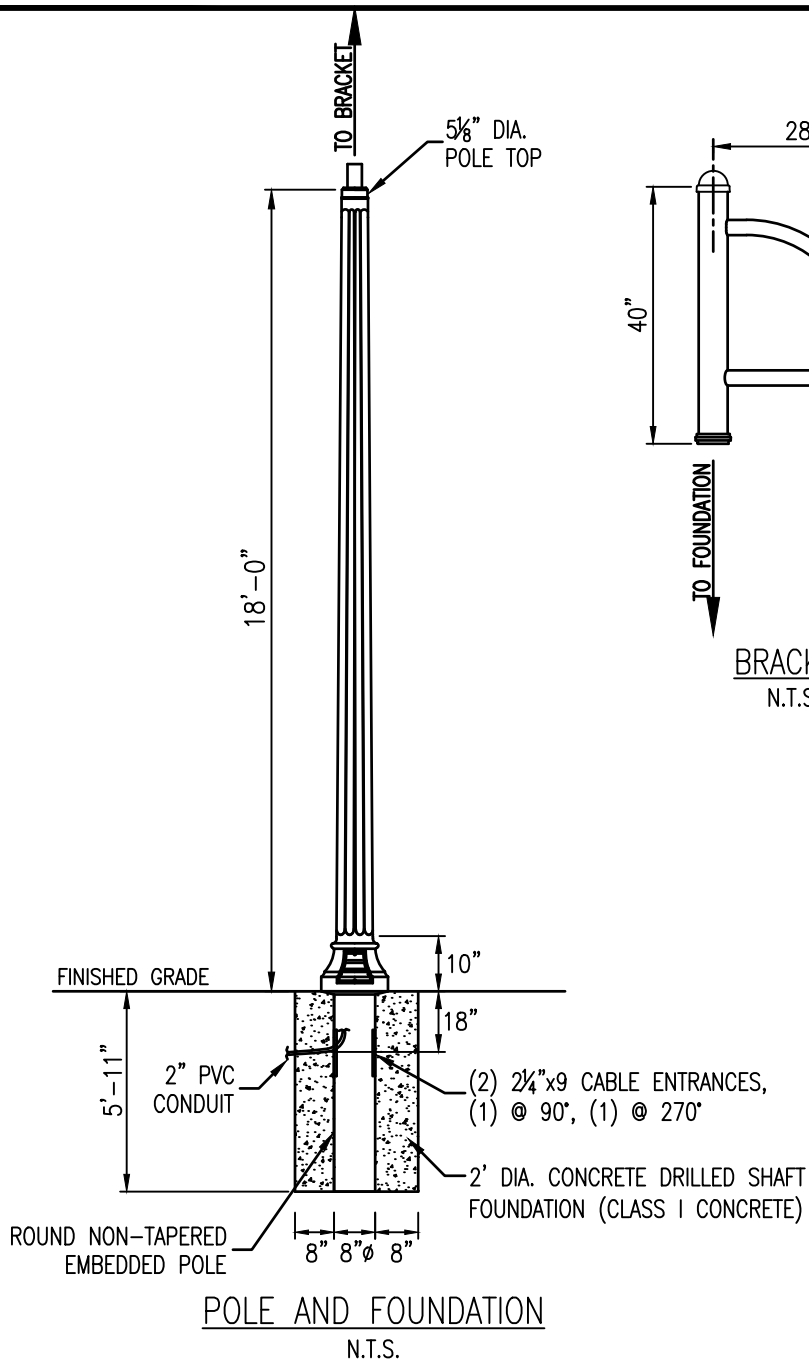

NOTES:

1. WIRING SHALL BE IN ACCORDANCE WITH THE FDOT STANDARD plans INDEX 715-001, LATEST EDITION.
2. POLE: AMERON CO. CAT. #VEF5.5(233A)T6; TENON SIZE 4" DIA. X 9" LONG WITH ACRYLIC ANTI-GRAFFITI COATING OR APPROVED EQUAL.
3. FIXTURE: LUMEC CO. CAT. #DMS50-80W48LED-4K-T-LE3F-240-GB2TX OR APPROVED EQUAL.
4. BRACKET: LUMEC CO. CAT. #VR308-1A-BG2TX OR APPROVED EQUAL.
5. FOUNDATION: 3,000 PSI MIN. CLASS I CONC, 2' DIA., 5'-11" DEEP W/ POLE DIRECTLY EMBEDDED. APPROX. 0.61 CY EA.



MARTIN COUNTY PUBLIC WORKS - STANDARD DETAILS

STREET LIGHT

DETAIL

R-130

DATE: 04/23/19

MAINTENANCE OF TRAFFIC CONTROL DEVICES

TRAFFIC SIGNS ON PRIVATELY MAINTAINED ROADS ARE THE RESPONSIBILITY OF THE MAINTAINING ENTITY, TYPICALLY, THE HOMEOWNERS OR PROPERTY OWNERS ASSOCIATION. WHERE PRIVATELY MAINTAINED ROADS INTERSECT STATE OR COUNTY MAINTAINED ROADS, THE TRAFFIC SIGNS (SUCH AS STREET NAME "BLADES" AND REGULATORY SIGNS) AND MARKINGS (SUCH AS STOP BARS) "SHALL BE THE RESPONSIBILITY OF THE PROPERTY OWNER AND CURRENT USER ENTITY" NOT THE COUNTY OR THE STATE. PRIOR TO THE MARTIN COUNTY SHERIFF'S OFFICE PATROLLING ON PRIVATE ROADS, AN AGREEMENT FOR TRAFFIC CONTROL ON PRIVATE ROADS MUST BE EXECUTED WITH MARTIN COUNTY. THE HOMEOWNERS OR PROPERTY OWNERS ASSOCIATION SHALL SUBMIT A CERTIFICATION OF COMPLIANCE WITH THESE REGULATIONS PRIOR TO THE EXECUTION OF THE AGREEMENT FOR TRAFFIC CONTROL ON PRIVATE ROADS; THE CERTIFICATION MUST BE SIGNED AND SEALED BY A PROFESSIONAL ENGINEER LICENSED IN THE STATE OF FLORIDA.

THE DESIGN AND MANUFACTURING OF ALL SIGNING AND MARKINGS REQUIRED FOR THE OPERATION OF THE CONNECTION (SUCH AS STOP BARS AND STOP SIGNS FOR THE CONNECTION) SHALL BE THE RESPONSIBILITY OF THE PROPERTY OWNER AND CURRENT ENTITY RESPONSIBLE FOR THE CONNECTION, OR GOVERNMENTAL ENTITY HAVING JURISDICTION OVER THE CONNECTION, ROAD, OR INTERSECTION OF THE COUNTY ROAD REGARDLESS OF THE OWNER OF THE RIGHT-OF-WAY AS PROVIDED IN CHAPTER 316, FLORIDA STATUTES.

ALL TRAFFIC CONTROL DEVICES INSTALLED ON COUNTY OR PRIVATELY MAINTAINED ROADS SHALL BE IN CONFORMANCE WITH THE MANUAL ON UNIFORM TRAFFIC CONTROL DEVICES (MUTCD), THE FLORIDA DEPARTMENT OF TRANSPORTATION (FDOT) STANDARD PLANS, AND THESE STANDARDS.

PLACEMENT OF TRAFFIC CONTROL DEVICES

PER FLORIDA STATUTE 316.0747, THE PLACEMENT OR POSITION OF TRAFFIC CONTROL DEVICES ALONG ROADS WHERE THE PUBLIC IS INVITED, INCLUDING THOSE DEVICES INSTALLED ON PRIVATE PROPERTY, SHALL MEET THE STATE STANDARDS ADOPTED BY THE FDOT, WHICH INCLUDES THOSE IDENTIFIED IN THE MUTCD. IF THE STANDARD POSITION CANNOT BE ATTAINED DUE TO IMMOBILE OBSTRUCTIONS, ALTERNATIVE PLACEMENT MAY BE PERMITTED BY THE COUNTY ENGINEER.

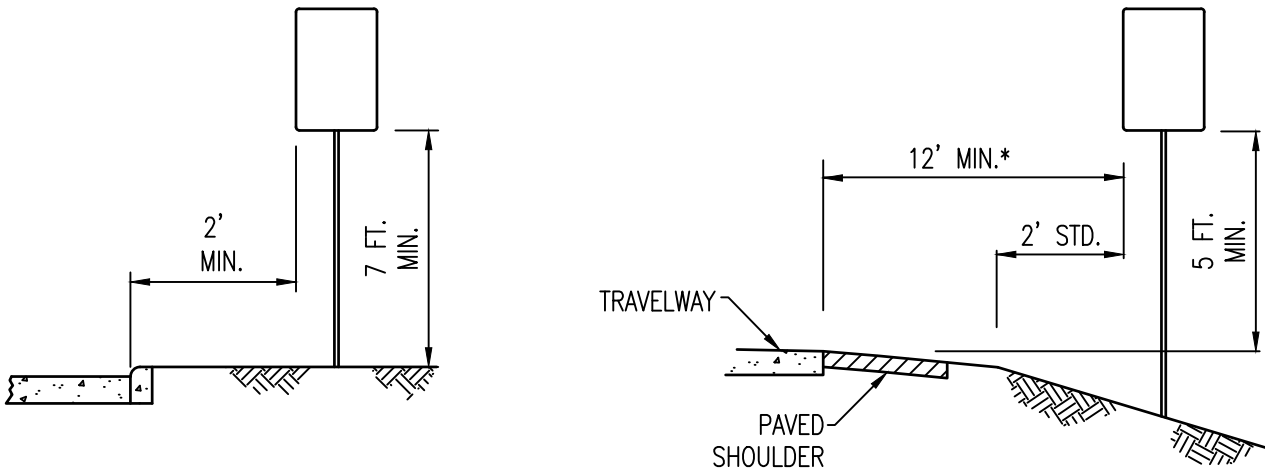

*THE SETBACK FOR STOP OR YIELD SIGNS MAY BE REDUCED TO 3' MINIMUM FROM THE DRIVING LANE IF REQUIRED FOR VISIBILITY IN BUSINESS OR RESIDENTIAL AREAS WITH NO CURB AND SPEEDS OF 30 MPH OR LESS



MARTIN COUNTY PUBLIC WORKS - STANDARD DETAILS

TRAFFIC CONTROL

DETAIL

R-140A

DATE: 04/23/19

SIGNS AND MARKINGS



R1-1

INSTALLATION OF STOP SIGNS SHALL BE IN ACCORDANCE WITH THE SECTION 28.04 OF THE MUTCD. MULTI-WAY STOP SIGNS SHALL BE PLACED ONLY IF APPLICABLE IN ACCORDANCE WITH SECTION 28.07 OF THE MUTCD. STOP SIGNS ARE USED TO INDICATE THAT TRAFFIC IS ALWAYS REQUIRED TO STOP AND SHOULD NEVER BE USED TO SLOW OR CALM TRAFFIC FLOW. STOP SIGNS SHALL BE OCTAGONAL AND AT LEAST 30 INCHES HIGH BY 30 INCHES WIDE WITH WHITE DIAMOND GRADE SHEETING BACKGROUND AND CLEAR RED ELECTRO CUT OVERLAY OR SILKSCREENED WITH CLEAR ULTRAVIOLET RESISTANT OVERLAY.

A STOP BAR OR LINE IS REQUIRED AT EACH LOCATION WHERE A STOP SIGN EXISTS. THE STOP BAR SHALL CONSIST OF A SOLID 24-INCH WIDE WHITE THERMOPLASTIC LINE THAT EXTENDS ACROSS THE APPROACH LANES TO INDICATE THE POINT AT WHICH THE STOP IS INTENDED OR REQUIRED TO BE MADE.



R1-2

YIELD SIGNS SHALL BE USED ONLY TO CONTROL MERGE MOVEMENTS AND TO ASSIGN THE RIGHT OF WAY AT THE ENTRANCE OF A ROUNDABOUT INTERSECTION. YIELD SIGNS ARE TRIANGULAR AND SHALL BE AT LEAST 36 INCHES ALONG EACH SIDE WITH WHITE DIAMOND GRADE SHEETING BACKGROUND AND CLEAR RED ELECTRO CUT OVERLAY OR SILKSCREENED WITH CLEAR ULTRAVIOLET RESISTANT OVERLAY.



R3-1

NO RIGHT TURN OR NO LEFT TURN SIGNS SHOULD BE PLACED WHERE THEY WILL BE MOST EASILY SEEN BY ROAD USERS WHO MIGHT BE INTENDING TO TURN. THESE SIGNS ARE THE ONLY SIGNS (OTHER THAN THE SUPPLEMENTAL PLAQUE) PERMITTED TO BE PLACED ON THE POST IN CONJUNCTION WITH A STOP OR YIELD WHEN LOCATED ON OR NEAR THE RIGHT CORNER OF THE INTERSECTION. TURN PROHIBITION SIGNS SHALL BE AT LEAST 24 INCHES HIGH BY 24 INCHES WIDE WITH WHITE DIAMOND GRADE SHEETING BACKGROUND AND CLEAR RED ELECTRO CUT OVERLAY OR SILKSCREENED WITH CLEAR ULTRAVIOLET RESISTANT OVERLAY.

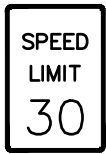

R2-1

SPEED LIMITS SHALL BE ESTABLISHED IN ACCORDANCE WITH THE FDOT' SPEED ZONING FOR HIGHWAYS, ROADS, AND STREETS IN FLORIDA. SPEED LIMIT SIGNS SHALL BE AT LEAST 30 INCHES HIGH BY 24 INCHES WIDE WITH WHITE DIAMOND GRADE SHEETING BACKGROUND OR SILKSCREENED WITH CLEAR ULTRAVIOLET RESISTANT OVERLAY.

THE MINIMUM POSTED SPEED IN MARTIN COUNTY IS 25 MPH; HOWEVER, SCHOOL ZONES MAY BE POSTED AT 20 MPH.



ONLY SCHOOL WARNING SIGNS, INCLUDING THE "SCHOOL" PORTION OF THE SCHOOL SPEED LIMIT SIGN AND INCLUDING ANY SUPPLEMENTAL PLAQUES USED IN ASSOCIATION WITH THESE WARNING SIGNS, SHALL HAVE A FLUORESCENT YELLOW-GREEN BACKGROUND WITH A BLACK LEGEND AND BORDER.

ALL OTHER WARNING SIGNS SHALL HAVE A FLUORESCENT YELLOW BACKGROUND WITH A BLACK LEGEND AND BORDER.



THE DEAD END SIGN (OR FLAG ON A STREET NAME) BLADE SHALL BE USED AT THE ENTRANCE OF A SINGLE ROAD OR STREET THAT TERMINATES IN A DEAD END OR CUL-DE-SAC.



THE NO OUTLET SIGN (OR FLAG ON A STREET NAME BLADE) SHALL BE USED AT THE ENTRANCE TO A ROAD OR ROAD NETWORK FROM WHICH THERE IS NO OTHER EXIT.



THE TOP PORTION OF THE PARKING BY DISABLED PERMIT ONLY SIGN SHALL DISPLAY WHITE REFLECTIVE LEGEND AND BORDER WITH A BLUE REFLECTIVE BACKGROUND. THE BOTTOM PORTION OF THE SIGN SHALL DISPLAY AN OPAQUE BLACK LEGEND AND BORDER WITH A REFLECTIVE WHITE BACKGROUND. SIGN FABRICATION SHALL CONSIST OF ONE PANEL.



MARTIN COUNTY PUBLIC WORKS - STANDARD DETAILS

TRAFFIC CONTROL

DETAIL

R-140B

DATE: 04/23/19

STREET NAME BLADES

RECOMMENDED MINIMUM LETTER HEIGHTS ON STREET NAME BLADES

<u>TYPE OF MOUNTING</u>	<u>TYPE OF STREET OR HIGHWAY</u>	<u>SPEED LIMIT</u>	<u>RECOMMENDED MINIMUM LETTER HEIGHT (IN INCHES)</u>	
			<u>INITIAL UPPER-CASE</u>	<u>LOWER-CASE</u>
OVERHEAD	ALL TYPES	ALL SPEED LIMITS	12	9
POST-MOUNTED	MULTI-LANE	MORE THAN 40 MPH	8	6
POST-MOUNTED	MULTI-LANE	40 MPH OR LESS	6	4.5
POST-MOUNTED	2-LANE	ALL SPEED LIMITS	*6	*4.5



D3-1

*ON LOCAL TWO-LANE STREETS WITH SPEED LIMITS OF 25 MPH, 4-INCH INITIAL UPPER-CASE LETTERS WITH 3-INCH LOWER-CASE LETTERS MAY BE USED.

ON COUNTY MAINTAINED ROADS THE LETTERING SHALL BE HIGHWAY C OR HIGHWAY B FONT. ALL LETTERING SHALL BE AT LEAST 1 INCH FROM THE TOP, BOTTOM, AND EACH SIDE OF THE BLADE. ABBREVIATIONS SHALL BE LIMITED TO THOSE THAT ARE COMMONLY RECOGNIZED AND UNDERSTOOD. THE SUPPLEMENTARY LETTERING INDICATING THE COUNTY QUADRANT OR STREET TYPE SHALL BE SUPER-SCRIPTED UPPER CASE AND ONE-HALF THE HEIGHT OF THE INITIAL UPPERCASE LETTER(S). UNLESS SPECIFICALLY STATED OTHERWISE, THE BORDER SHALL BE WHITE AND SHALL BE AT LEAST 1/2 INCH INSIDE THE EDGE OF THE BLADE. THE CORNERS OF THE BLADE SHALL BE ROUNDED. ALL STREET NAME BLADES SHALL BE MADE OF 0.063 ALUMINUM WITH WHITE DIAMOND GRADE SHEETING BACKGROUND AND GREEN ELECTRO-CUT OVERLAY. TWO BLADES SHALL BE MOUNTED BACK-TO-BACK ON A SQUARE POST WITH TWO 5/16 x 2-3/4 BOLTS WITH NYLON WASHERS AND LOCK WASHERS PLUS ONE 5/16 x 3/4 BOLT WITH A NYLON WASHER AND LOCK WASHER AT EACH END OF THE BLADES.

ON NON-COUNTY (OR NON-STATE) MAINTAINED ROADS THE BACKGROUND MUST BE EITHER BLUE OR BROWN WITH WHITE LETTERING OR WHITE WITH BLACK LETTERING.



MARTIN COUNTY PUBLIC WORKS - STANDARD DETAILS

TRAFFIC CONTROL

DETAIL

R-140C

DATE: 04/23/19

ON COUNTY MAINTAINED ROADS

ALL PAVEMENT MARKINGS SHALL BE THERMOPLASTIC AND PAVEMENT STRIPES SHALL BE AT LEAST 6 INCHES WIDE, WHETHER WHITE OR YELLOW.

ALL SIGN POSTS SHALL BE 2"x2"x14GA. ASTM A653 GALVANIZED STEEL SHEET GRADE 50, "MODIFIED TO GRADE 55". GALVANIZED COATING SHALL HAVE A G90 THICKNESS (0.90 OUNCES OF COATING PER SQUARE FOOT OF COVERAGE). CORNER WELD BY HIGH FREQUENCY ELECTRIC RESISTANCE, THEN SCARF TO MATCH FORMED RADIUS. ZINC COAT WELD AFTER SCARFING. APPLY 0.5 MIL CLEAR COAT ACRYLIC POLYMER TO OUTER SURFACE. SIGN PLACEMENT SHALL BE IN A SAND BEDDING

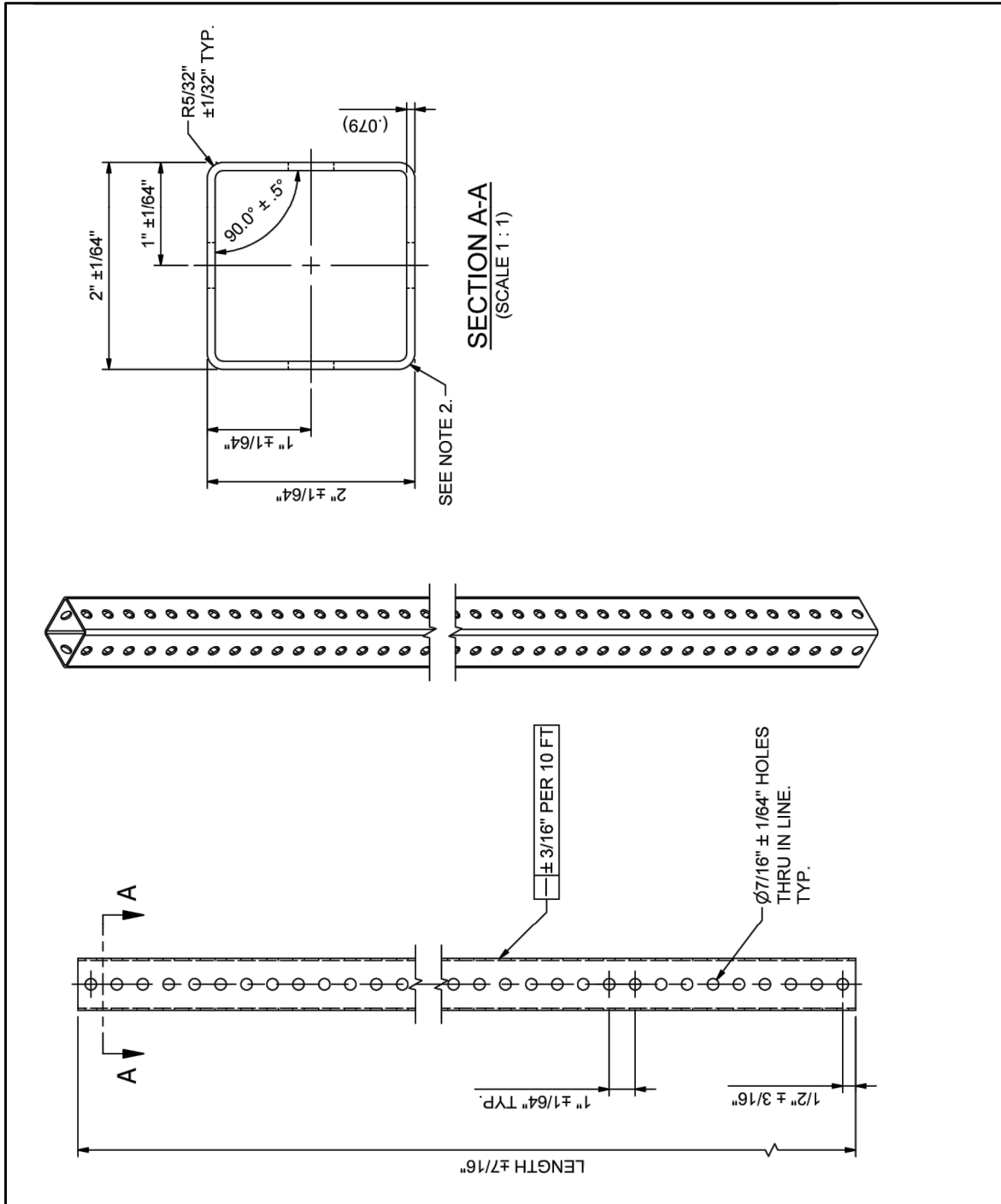

MARTIN COUNTY PUBLIC WORKS - STANDARD DETAILS

TRAFFIC CONTROL

DETAIL

R-140D

DATE: 04/23/19

CONTROLLER ASSEMBLY:

- 1) ECONOLITE TS-2, TYPE 1 "PLUG-N-GO" TRAFFIC CABINET ASSEMBLY. SIZE 7 CABINET (72"HX44"WX24"D) WITH (3) SHELVES
- 2) INTEGRATED DRAWER/COMPUTER SHELF
- 3) ECONOLITE COBALT TS-2, TYPE 2 (WITH ABC CONNECTORS) CONTROLLER
- 4) SDLC COMMUNICATIONS PANEL.
- 5) MALFUNCTION MANAGEMENT UNIT - ECONOLITE (OR) EDI MMU2-16LEIP
- 6) CONFIGURATION #4, 16 LOAD BAY MAIN PANEL (SOP10) (PHASES 1-8, OVERLAPS A,B,C,D AND PED 2, 4, 6 & 8)
- 7) CONFIGURATION #2, 16 DETECTOR RACK
- 8) LED CABINET LIGHTING SYSTEM
- 9) SIMENS/RUGGEDCOM RS 900G - HI - D - 2SFP SWITCH FOR COMMUNICATION
- 10) PREEMPT PANEL/RELAY REQUIRED
- 11) GENERATOR COMPARTMENT/TRANSFER SWITCH TO BE BUILT INTO CABINET

FOR ORDERING AND PRICING INFORMATION PLEASE CONTACT:

MATT JOSEPH

ECONOLITE, INC.

TEL: (904) 448-5619

(CELL) (904) 334-5891

MARTIN COUNTY TRAFFIC SIGNAL SPECIFICATIONS

1. ALL WORK TO BE IN ACCORDANCE WITH THE LATEST EDITION OF: A) FDOT "DESIGN STANDARDS" B) "STANDARD SPECIFICATIONS FOR ROAD AND BRIDGE CONSTRUCTION" C) THE "NATIONAL ELECTRIC CODE" D) "MANUAL OF UNIFORM TRAFFIC CONTROL DEVICES". ALL TRAFFIC SIGNAL EQUIPMENT INSTALLED IS TO BE DONE BY A QUALIFIED SIGNAL CONTRACTOR WITH A MINIMUM LEVEL II IMSA TRAFFIC SIGNAL CERTIFICATION. LEVEL II CERTIFIED TECHNICIAN IS TO BE ON-SITE DURING ALL CABINET, SIGNAL, VIDEO DETECTOR CAMERA WIRING FOR ANY PROJECT IN MARTIN COUNTY.
2. MARTIN COUNTY REQUIRES ALL NEW TRAFFIC SIGNALS TO BE MAST ARM INSTALLATIONS. ALL MAST ARM INSTALLATIONS TO MEET FDOT SPECIFICATIONS AND HAVE THE COLOR OF "VERDE GREEN". THE PAINT APPLICATION SHALL BE WARRANTED FOR FIVE (5) YEARS AS SPECIFIED IN FDOT SECTION 649. THE DESIRED MAST-ARM ATTACHMENT HEIGHT IS 20 FEET FOR PROPER MOUNTING OF SIGNALS, UNLESS THERE ARE SPECIFIC ELEVATION DISCREPANCIES REQUIRING A DIFFERENT ATTACHMENT HEIGHT.
3. ALL MAST ARM UPRIGHTS TO HAVE A 20-POSITION TERMINAL STRIP COMPARTMENT AT THE BASE. TERMINAL STRIPS/SCREWS TO BE STAINLESS STEEL. STAINLESS STRAIN RELIEF DEVICES ARE TO ENCLOSE ALL SIGNAL CABLES WITHIN MAST ARM UPRIGHT AND BE ATTACHED TO THE J-HOOK.
4. ALL PEDESTRIAN SIGNALS SHALL BE LED COUNTDOWN WITH ONE-SECTION, INTERNATIONAL SYMBOL WITH "HAND/MAN" SIDE BY SIDE. LED INDICATIONS ARE TO BE ON FDOT APL AND HAVE 5 YEAR WARRANTY.
5. ALL TRAFFIC SIGNALS TO BE EAGLE BRAND (OR APPROVED EQUIVALENT) "LIGHTWEIGHT" TYPE WITH LED INDICATIONS IN ALL COLORS. LED INDICATIONS ARE TO BE ON FDOT APL AND HAVE 15 YEAR WARRANTY. BACK PLATES ARE NOT SPECIFIED BY MARTIN COUNTY. MAST ARMS SHALL HAVE ALL SIGNAL BUCKETS AS POLYCARBONATE AND SPAN WIRE INSTALLATIONS SHALL HAVE AN ALUMINUM RED SIGNAL BUCKET WITH POLYCARBONATE AMBER AND GREEN SIGNAL BUCKETS.
6. ALL RELAYS IN CABINETS TO BE SOCKET-MOUNTED.



MARTIN COUNTY PUBLIC WORKS - STANDARD DETAILS

TRAFFIC SIGNAL SPECIFICATIONS

DETAIL

R-150A

DATE: 04/23/19

MARTIN COUNTY TRAFFIC SIGNAL SPECIFICATIONS (cont'd)

7. ALL STREET NAME SIGNS TO MEET FDOT "SAFE MOBILITY FOR LIFE PROGRAM" AND BE RIGIDLY MOUNTED TO MAST ARMS, WHERE APPLICABLE. SIGNS SHALL BE LED AND ON FDOT APL.
8. MARTIN COUNTY REQUIRES ECONOLITE AUTOSCOPE VISION VIDEO DETECTION SYSTEM TO MEET SYSTEM COMPATIBILITY. ALL CAMERA INSTALLATION LOCATIONS SHALL BE APPROVED BY MARTIN COUNTY TRAFFIC DIVISION PRIOR TO INSTALLATION. AT MARTIN COUNTY'S DISCRETION, LOOPS MAY BE PLACED IN LIEU OF THE VIDEO DETECTION EQUIPMENT. IF LOOPS ARE USED, ALL SIDE STREET AND LEFT-TURN LOOPS SHALL BE TYPE F, 6'X40'. MAIN STREET SHALL INCLUDE TYPE F, 6'X20' AND/OR TYPE B, 6'X6' ADVANCE LOOPS.
9. MAINTENANCE OF TRAFFIC MUST INCLUDE COST OF ANY TEMPORARY SIGNALIZATION WORK AND FOLLOW M.U.T.C.D. GUIDELINES. ANY NEW SIGNAL INSTALLATION SHALL HAVE VMS MESSAGE BOARDS PLACED AT LEAST ONE WEEK IN ADVANCE TO ALERT MOTORISTS OF NEW SIGNAL ACTIVATION DATE. TURN-ON DATE TO BE APPROVED BY COUNTY ENGINEER. ANY TRAFFIC SIGNALS "UTILITIES" THAT PRESENT CONSTRUCTION CONFLICTS ARE TO BE INCORPORATED AS PART OF THE PROJECT AND CORRECTED/RELOCATED BY THE CONTRACTOR. UTILITY LOCATES ARE CONSIDERED APPROXIMATE AND CONTRACTOR SHALL POT-HOLE FOR VERIFICATION PRIOR TO DRILL SHAFT, DIRECTIONAL BORE, OR TRENCHING OPERATIONS.

MAINTENANCE OF TRAFFIC (M.O.T.) LANE CLOSURES FOR ARTERIAL OR COLLECTOR ROADS:

WHEN AN ARTERIAL OR COLLECTOR ROAD IS TO HAVE A LANE CLOSURE AS A PART OF ITS M.O.T. PLAN, THE FOLLOWING CONDITIONS SHALL APPLY IN ADDITION TO ALL OTHER M.O.T. REQUIREMENTS:

- LANE CLOSURES SHALL BE LIMITED TO BETWEEN THE HOURS OF 9:00AM TO 3:30PM, AND 7:00PM TO 6:00AM.
- THE CONTRACTOR SHALL INCLUDE AS A PART OF THE M.O.T. PLAN A TRAFFIC CONTROL OFFICER PROVIDED BY EITHER THE LOCAL POLICE DEPARTMENT OR THE MARTIN COUNTY SHERIFF'S OFFICE. THE TRAFFIC CONTROL OFFICER SHALL BE ON-SITE 100% OF THE TIME DURING ALL LANE CLOSURES.
- IF THE CONTRACTOR BEGINS A LANE CLOSURE BEFORE THE APPROVED START TIME OR ENDS THE LANE CLOSURE AFTER THE APPROVED LANE CLOSURE TIME THE CONTRACTOR MAY BE ASSESSED BY THE COUNTY DAMAGES OF \$1,500.00 PER HOUR FOR EACH HOUR LANE CLOSURE OUTSIDE THE ABOVE STATED APPROVED TIME RANGE. DAMAGE FEES MAY BE ASSESSED AND PRORATED TO THE NEXT QUARTER HOUR, I.E. A CONTRACTOR THAT ENDS AN APPROVED LANE CLOSURE AT 3:40PM MAY BE ASSESSED \$375.00 (\$1,500 X 0.25).
- LANE CLOSURES THAT ARE IMPLEMENTED BY THE CONTRACTOR WITHOUT THE PRESENCE OF A TRAFFIC CONTROL OFFICER MAY BE ASSESSED \$500.00 PER HOUR.
- LANE CLOSURES THAT ARE IMPLEMENTED BY THE CONTRACTOR THAT ARE NOT PRE-AUTHORIZED IN WRITING BY THE COUNTY ENGINEER MAY BE ASSESSED \$3,000.00 PER HOUR.

IF PRIOR WRITTEN AUTHORIZATION TO MODIFY THE ALLOWABLE WORK HOURS IS OBTAINED, THE ABOVE LISTED ASSESSMENTS OF COST WILL BE ADJUSTED TO REFLECT THE AUTHORIZED WORK HOURS.

10. SIGNALS INTERCONNECT CABLE SHALL BE 144 COUNT, SINGLE MODE FIBER OPTIC CABLE. EACH CABINET LOCATION SHALL HAVE A 6 COUNT, SINGLE-MODE DROP CABLE FROM CABINET TO SPLICE ENCLOSURE. THE PATCH PANEL FOR USE INSIDE THE CABINET SHALL BE CORNING SPH-01P. FOR ADDITIONAL INFORMATION, SEE MARTIN COUNTY ATMS DESIGN/BUILT REQUIREMENTS.
11. SIEMENS/RUGGEDCOM BRAND FIBER OPTIC ETHERNET SWITCH, MODEL RS 900G-HI-D-2SFP SHALL BE INCLUDED WITH EACH TRAFFIC SIGNAL CABINET. UPS BATTERY BACK-UP DEVICE SHALL BE INCLUDED WITH EACH TRAFFIC SIGNAL CABINET AND BE TRIPP-LITE MODEL AVR750U. WHERE SPECIFIED, THE UPS BATTERY BACKUP SHALL BE ECONOLITE ZINC BLUE BBS (TO INCLUDE NEMA CONTROLLER, NEMA BATTERY, AND POWER INTERFACE MODULE).



MARTIN COUNTY PUBLIC WORKS - STANDARD DETAILS

TRAFFIC SIGNAL SPECIFICATIONS

DETAIL

R-150B

DATE: 04/23/19

MARTIN COUNTY TRAFFIC SIGNAL SPECIFICATIONS (cont'd)

12. IF TEMPORARY SPAN WIRE INSTALLATION, ALL DISCONNECT WIRING HARNESSSES SHALL BE COMPLETELY REMOVED FROM DISCONNECTS AND SIGNALS TO BE HARDWIRED. MARTIN COUNTY REQUIRES ENGINEERED CASTINGS BRAND OR APPROVED EQUAL DISCONNECTS.
13. 5-SECTION, RIGHT-TURN SIGNALS ARE NOT PERMITTED UNLESS APPROVED BY THE COUNTY ENGINEER.
14. ALL PULL BOXES ARE TO BE LOAD-BEARING, 20,000 LB, COMPOSITE-TYPE LIDS (NO METAL LIDS). UNLESS OTHERWISE INDICATED ON THE PLANS, TRAFFIC SIGNAL PULL BOXES SHALL BE 13"X24" IN PLAN. FIBER OPTIC PULL BOXES ARE DETAILED IN R-160 SERIES.
15. ONE SET OF AS-BUILTS IS TO BE PROVIDED IN AUTOCAD VERSION 2018.
16. PAY ITEM 641-11-114, ELECTRIC SERVICE POLE, IS REQUIRED AT EACH SIGNAL INSTALLATION TO MOUNT THE ELECTRICAL SERVICE DISCONNECT.

GENERAL WORKMANSHIP FOR INSTALLATION AND MAINTENANCE REQUIREMENTS

ALL WORK IS TO BE PERFORMED IN A WORKMANLIKE MANNER. IT IS THE CONTRACTOR'S RESPONSIBILITY TO PROVIDE THE SKILLED LABOR, IN THE APPROPRIATE AREAS NECESSARY, TO PROVIDE AN ACCEPTABLE AND PROFESSIONAL FINISHED PRODUCT. THE CONTRACTOR AND HIS PERSONNEL SHALL HAVE, AT ALL TIMES, ALL THE NECESSARY PAPERWORK, EQUIPMENT, AND TOOLS NEEDED TO COMPLETE THE JOB. IT IS EXPECTED THAT PLUMB SURFACES SHALL BE PLUMB. SPACING OF MULTIPLE COMPONENTS, SUCH AS CONDUIT STUBS OR STRAPS, SHALL BE MADE IN EQUAL INCREMENTS. ALL MATERIALS SHALL BE NEW. ALL MAST ARM POLE ASSEMBLIES, PEDESTRIAN POLES, AND SUPPLEMENTAL SIGNAL POLES SHALL BE LEVELED TO THE SATISFACTION OF THE MARTIN COUNTY TRAFFIC SIGNAL AND LIGHT SUPERVISOR.

THE MARTIN COUNTY TRAFFIC SIGNAL AND LIGHT SUPERVISOR SHALL HAVE THE AUTHORITY TO MAKE FINAL DETERMINATION ON WHETHER WORKMANSHIP, MATERIALS, AND/OR FINAL PRODUCT(S) MEET THE SPECIFICATIONS CONTAINED HEREIN.

SURFACE TREATMENTS

* THREADED HARDWARE:

ALL NON-ELECTRICAL THREADED HARDWARE (I.E. ALL ASTRO BRAC HARDWARE, POLE HARDWARE, OR ANY THREADED SURFACE) SHALL BE COATED WITH PERMATEX ANTI-SEIZE LUBRICANT, OR COUNTY-APPROVED EQUIVALENT. NO SPRAY ON ANTI-SEIZE COMPOUND WILL BE ACCEPTED. THE AMOUNT OF ANTI-SEIZE BEING APPLIED SHALL BE SUFFICIENT ENOUGH TO BE VISIBLY SEEN.

* WEATHERPROOFING:

IRREGULAR MATING SURFACES SHALL BE RENDERED WEATHERPROOF BY APPLYING AN APPROPRIATE BEAD OF CLEAR SILICONE CAULK, SUCH AS SILICONE II, OR COUNTY-APPROVED EQUIVALENT. THESE AREAS INCLUDE SERRATED SIGNAL COUPLINGS, CONTROLLER CABINET FOUNDATION, PEDESTRIAN PUSH BUTTONS, AND ANY OTHER AREAS TYPICALLY PRONE TO MOISTURE INFILTRATION.

* CABLE ENTRY/EXIT:

WHEREVER A CABLE ENTERS OR EXITS A FIELD-DRILLED HOLE, THE HOLE SHALL BE PROTECTED BY A PERMANENTLY INSTALLED RUBBER GROMMET.



MARTIN COUNTY PUBLIC WORKS - STANDARD DETAILS

TRAFFIC SIGNAL SPECIFICATIONS

DETAIL

R-150C

DATE: 04/23/19

FIBER OPTIC TECHNICAL SPECIFICATIONS:

- 1) PATCH PANEL
 - CORNING SPH-01P WITH 6 ST CONNECTORS AT DROP AND REPEAT LOCATIONS.
 - CORNING CCH-03U WITH 24 ST CONNECTORS AT HUB LOCATIONS.
- 2) DROP CABLE
 - 6 COUNT SINGLE MODE FIBER TERMINATED WITH ST CONNECTORS AT DROP AND REPEAT LOCATIONS.
 - 24 COUNT SINGLE MODE FIBER TERMINATED WITH ST CONNECTORS AT HUB LOCATIONS.
- 3) SPLICE ENCLOSURE
 - CORNING SCF-4C18-01 OR SCF-6C22-02. MODEL DEPENDS ON NUMBER OF SPLICES.
- 4) ANY FIBER OPTIC CABLE THAT IS FOUND TO BE DAMAGED SHALL BE REPLACED FROM SPLICE ENCLOSURE TO SPLICE ENCLOSURE LOCATED AT TRAFFIC SIGNAL OR IT VAULT LOCATIONS. NEW SPLICES SHALL NOT BE PERMITTED DUE TO THE ADDED LOSS AND DEGRADATION OF SIGNAL THAT IS INTRODUCED WITH EACH NEW SPLICE.
- 5) ALL FIBER OPTIC CABLE SHALL HAVE A 25 YEAR MANUFACTURER EXTENDED WARRANTY (UP TO 10 YEARS FOR ITS INSTALLATIONS). THE FIBER OPTIC WARRANTY SHALL BE PERFORMED BY A LANSCAPE NETWORK OF PREFERRED INSTALLERS CONTRACTOR AS CERTIFIED THROUGH CORNING'S "STRINGENT REQUIREMENTS FOR TECHNICAL AND FINANCIAL STRENGTH AND HAVE A PROVEN DEDICATION TO QUALITY INSTALLATIONS."
- 6) ALL FIBER SPLICING DIAGRAMS/SCHEMATICS AND FIBER NETWORK DESIGN FOR ANY PROJECTS TO BE PROVIDED BY MARTIN COUNTY'S CONTINUING SERVICES FIBER CONTRACTOR. THE CONTINUING SERVICES FIBER CONTRACTOR IS A BUILDING INDUSTRY CONSULTING SERVICE INTERNATIONAL (BICSI) REGISTERED COMMUNICATIONS DISTRIBUTIONS DESIGNER (RCDD). THE COST FOR THE NETWORK DESIGN SCHEMATICS SHALL BE INCUMBENT UPON THE SUBCONTRACTOR MAKING THE REQUEST AND SHALL BE A REQUIREMENT FOR ANY PROJECT WHICH WILL IMPACT MARTIN COUNTY'S FIBER OPTIC NETWORK. MARTIN COUNTY'S CONTINUING SERVICES FIBER CONTRACTOR SHALL COORDINATE THE NETWORK DESIGN WITH MARTIN COUNTY ENGINEERING AND IT STAFF.
- 7) ALL FIBER OPTIC WORK TO BE PERFORMED BY BICSI ITS INSTALLER 2 CERTIFIED TECHNICIANS.
- 8) PULL BOXES / VAULTS
 - 24"X36"X24" OPEN-BOTTOM PRECAST POLYMER CONCRETE VAULTS WITH 20,000 LB CONCRETE, BOLT-DOWN COVER LABELED "FIBER OPTICS" FOR ALL SPLICE ENCLOSURE LOCATIONS
 - 17"X30" BOXES TO BE USED AT INTERMEDIATE LOCATIONS WHERE NO SPLICE ENCLOSURE IS LOCATED

VIDEO SURVEILLANCE SPECIFICATIONS:

- 1) PAN, TILT AND ZOOM CAMERA
 - HIKVISION DS-2DF5232X-AEL IND/OUT PTZ 2MP/1080P IP CAM 32X D/N SMART TRACK IP66 24VACDS-2DF5232X-AEL (OR) APPROVED HIKVISION EQUIVALENT



MARTIN COUNTY PUBLIC WORKS - STANDARD DETAILS

TRAFFIC SIGNAL SPECIFICATIONS

DETAIL

R-150D

DATE: 04/23/19



MARTIN COUNTY PUBLIC WORKS - STANDARD DETAILS

FIBER OPTIC CONDUIT (PLAN)

DETAIL

R-160A

DATE: 04/23/19

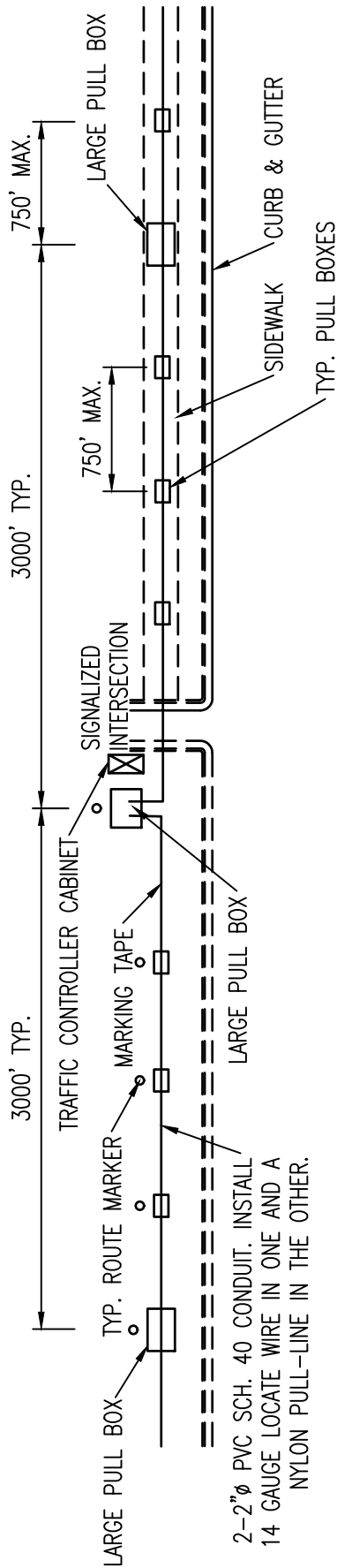

ROADWAY PLAN

1. THE DISTANCE BETWEEN TYPICAL PULL BOXES (17"x30"x12" DEEP) SHALL NOT EXCEED 750'. THE DISTANCE BETWEEN LARGE PULL BOXES (24"x36"x24" DEEP) SHALL BE 3000' +/- INTERVALS AND NEAR EACH TRAFFIC SIGNAL CONTROLLER CABINET, OR AS INDICATED ON THE PLANS. AT THESE LOCATIONS, THE LARGE PULL BOX TAKES THE PLACE OF THE TYPICAL PULL BOX.
2. FOR APPLICATIONS NOT COVERED IN THIS DETAIL THE CONTRACTOR SHALL REFER TO THE FDOT STANDARD SPECIFICATIONS FOR ROAD AND BRIDGE CONSTRUCTION.
3. ALL PULL BOXES AND LIDS SHALL BE HEAVY DUTY TRAFFIC BEARING FIBERGLASS COMPOSITE (RATED 20,000 POUNDS OVER TEN INCH SQUARE) PULL BOX LIDS SHALL BE STAMPED 'FIBER OPTIC'.
4. ENDS OF CONDUIT SHALL BE SEALED IN ACCORDANCE WITH SECTION 630 (CONDUIT) OF THE FDOT STANDARD SPECIFICATIONS FOR ROAD AND BRIDGE.
5. ONE RUN OF CONDUIT (BETWEEN PULL BOXES) SHALL NOT CONTAIN MORE THAN 360 DEGREES OF BEND INCLUDING PULL BOX BENDS.
6. MARKING TAPE: 3 INCHES WIDE MARKED 'CAUTION FIBER OPTIC'. TAPE SHALL BE ORANGE WITH BLACK 2-INCH HIGH BLOCK LETTERS ON NON-COLOR FADING MATERIAL. THE MARKING TAPE SHALL BE CONTINUOUS FROM PULL BOX TO PULL BOX.
7. FOR LOCATIONS WITH SINGLE CONDUIT, INSTALL A 14 GAUGE LOCATE WIRE; FOR LOCATIONS WITH MULTIPLE CONDUITS, INSTALL A 14 GAUGE LOCATE WIRE IN ONE OF THE CONDUITS AND A NYLON PULL LINES IN THE OTHERS. CONTACT TRAFFIC ENGINEERING FOR NUMBER OF DESIRED CONDUITS. MIN. COVER SHALL BE 36" UNDER PAVEMENT OR 30" UNDER SIDEWALK AND AREAS NOT EXPOSED TO VEHICULAR TRAFFIC.
8. STORE 200' OF FIBER OPTIC CABLE IN LARGE PULL BOXES AND 10' OF FIBER OPTIC CABLE IN TYPICAL PULL BOXES.

12" BED OF PEA ROCK OR CRUSHED STONE EXTENDS 6" BEYOND PULL BOX

INSTALL A ROUTE MARKER AT EVERY PULL BOX WHERE THE PULL BOX IS IN A GRASSED AREA. DO NOT INSTALL ROUTE MARKERS FOR PULL BOXES IN A SIDEWALK.

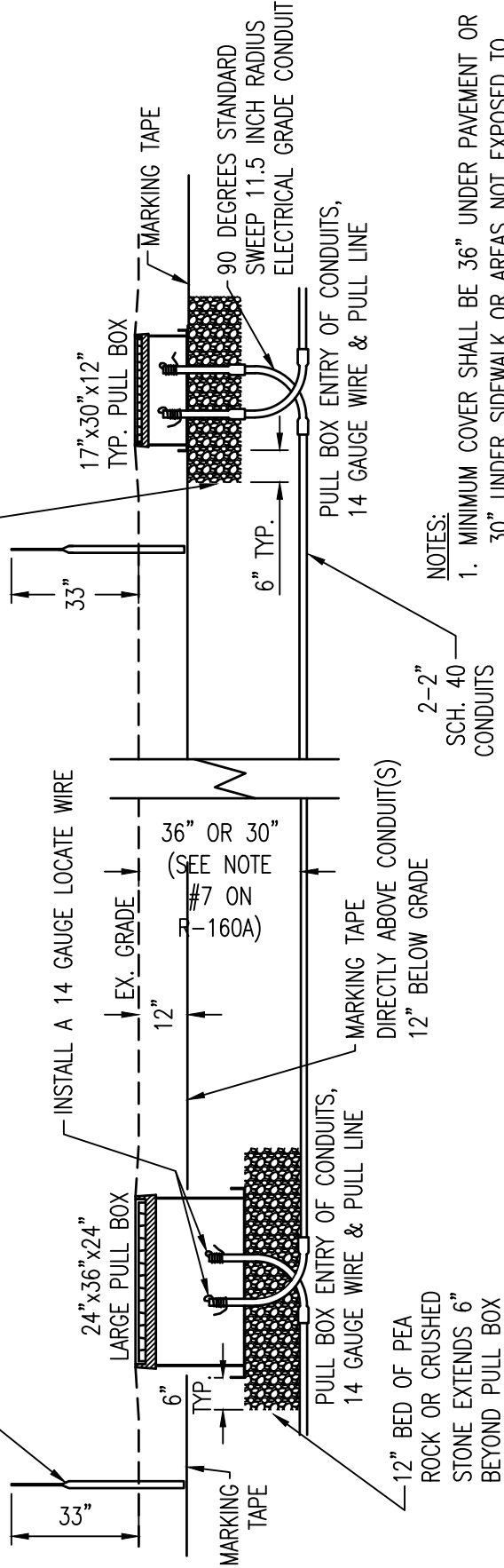

NOTES:

1. MINIMUM COVER SHALL BE 36" UNDER PAVEMENT OR 30" UNDER SIDEWALK OR AREAS NOT EXPOSED TO VEHICULAR TRAFFIC.

2-2" SCH. 40 CONDUITS

ROADWAY PROFILE

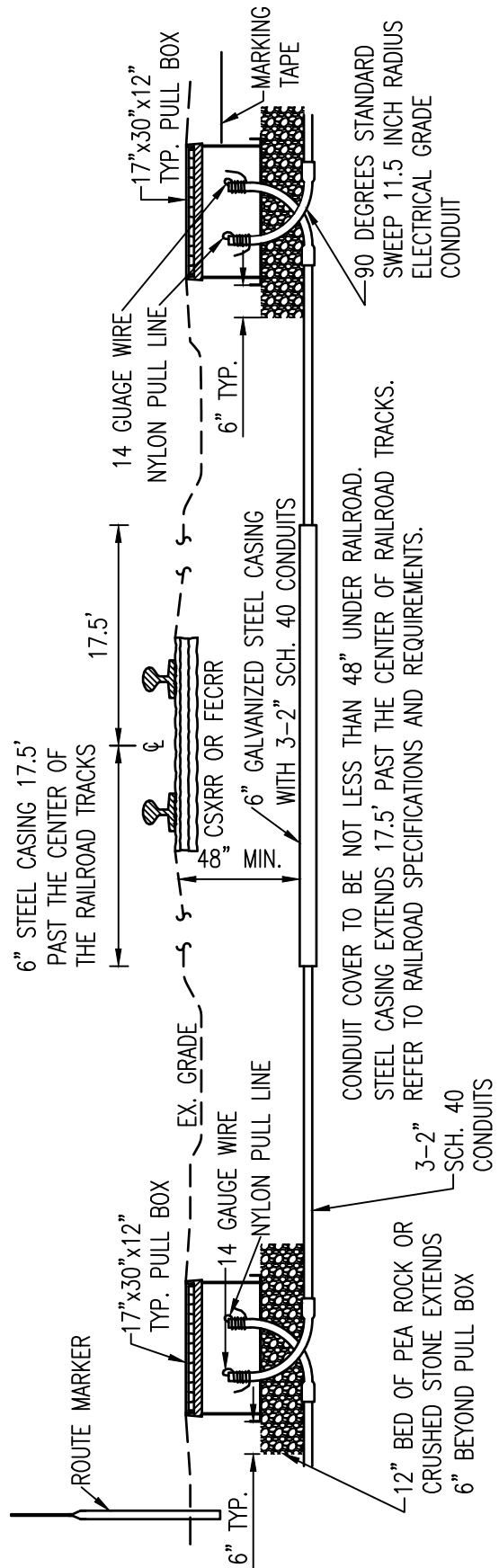

RAILROAD PROFILE



MARTIN COUNTY PUBLIC WORKS - STANDARD DETAILS

FIBER OPTIC CONDUIT (PROFILE)

DETAIL

R-160B

DATE: 04/23/19

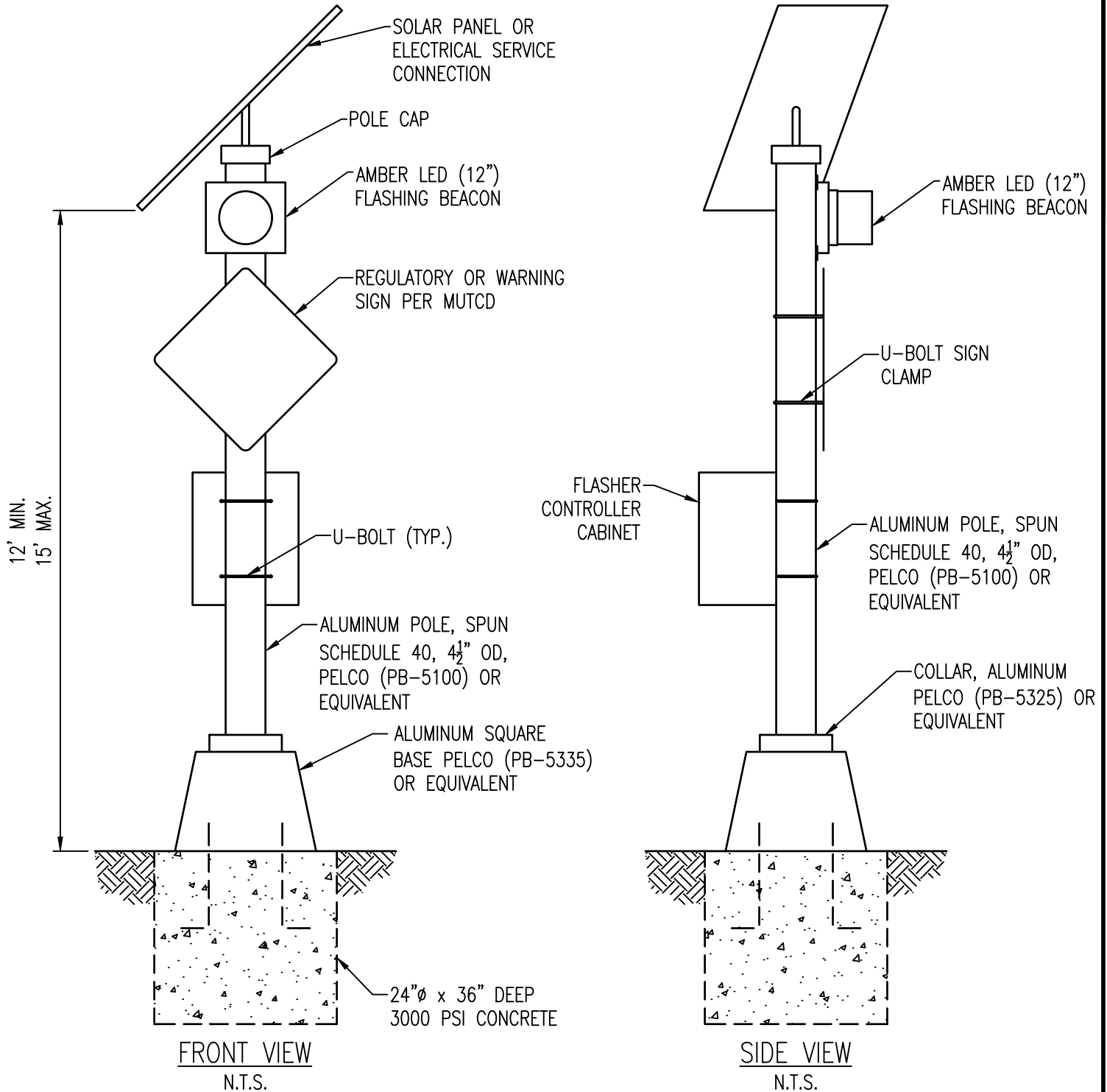

NOTES:

1. INSTALLATION LOCATIONS SHALL BE APPROVED BY COUNTY ENGINEER.
2. COMPONENTS SPECIFIED FOR INSTALLATION SHALL BE APPROVED BY COUNTY ENGINEER.
3. SOLAR FLASHER CABINET TO BE BY TRANSPORTATION CONTROL SYSTEMS OR EQUAL.
4. ALL FASTENERS TO BE STAINLESS STEEL.
5. UNLESS A DIFFERENT SPECIFICATION IS CALLED OUT HERE, COMPLIANCE WITH THE STANDARDS FOUND WITHIN FDOT STANDARD PLANS INDEX 700-120 IS REQUIRED.



MARTIN COUNTY PUBLIC WORKS - STANDARD DETAILS

FLASHING BEACON

DETAIL

R-170

DATE: 04/23/19

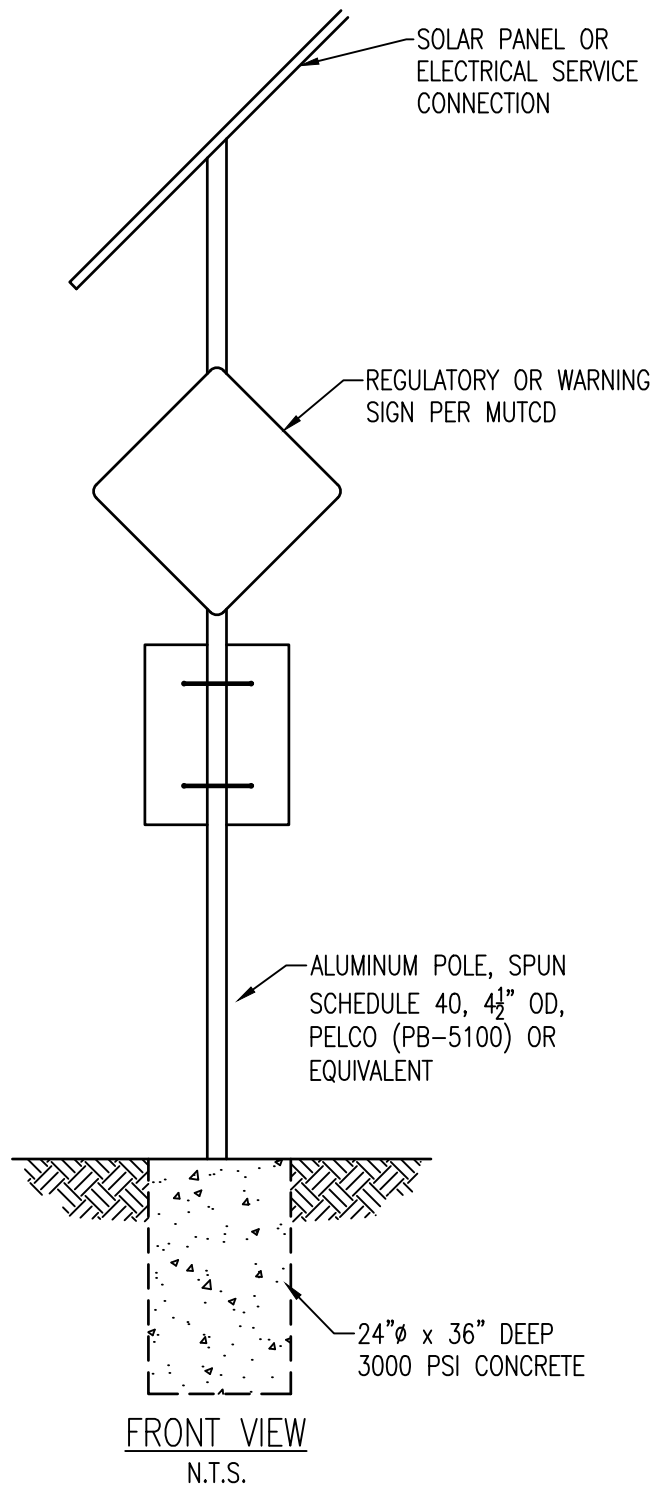

NOTES:

1. INSTALLATION LOCATIONS SHALL BE APPROVED BY COUNTY ENGINEER.
2. COMPONENTS AND CONFIGURATION SPECIFIED FOR INSTALLATION SHALL BE APPROVED BY COUNTY ENGINEER.
3. ALL FASTENERS TO BE STAINLESS STEEL.
4. PLACEMENT SHALL MEET THE STATE STANDARDS ADOPTED BY THE FDOT, WHICH INCLUDES THOSE IDENTIFIED IN THE MUTCD.



MARTIN COUNTY PUBLIC WORKS - STANDARD DETAILS

EDGE LIT SIGN

DETAIL

R-171

DATE: 04/23/19

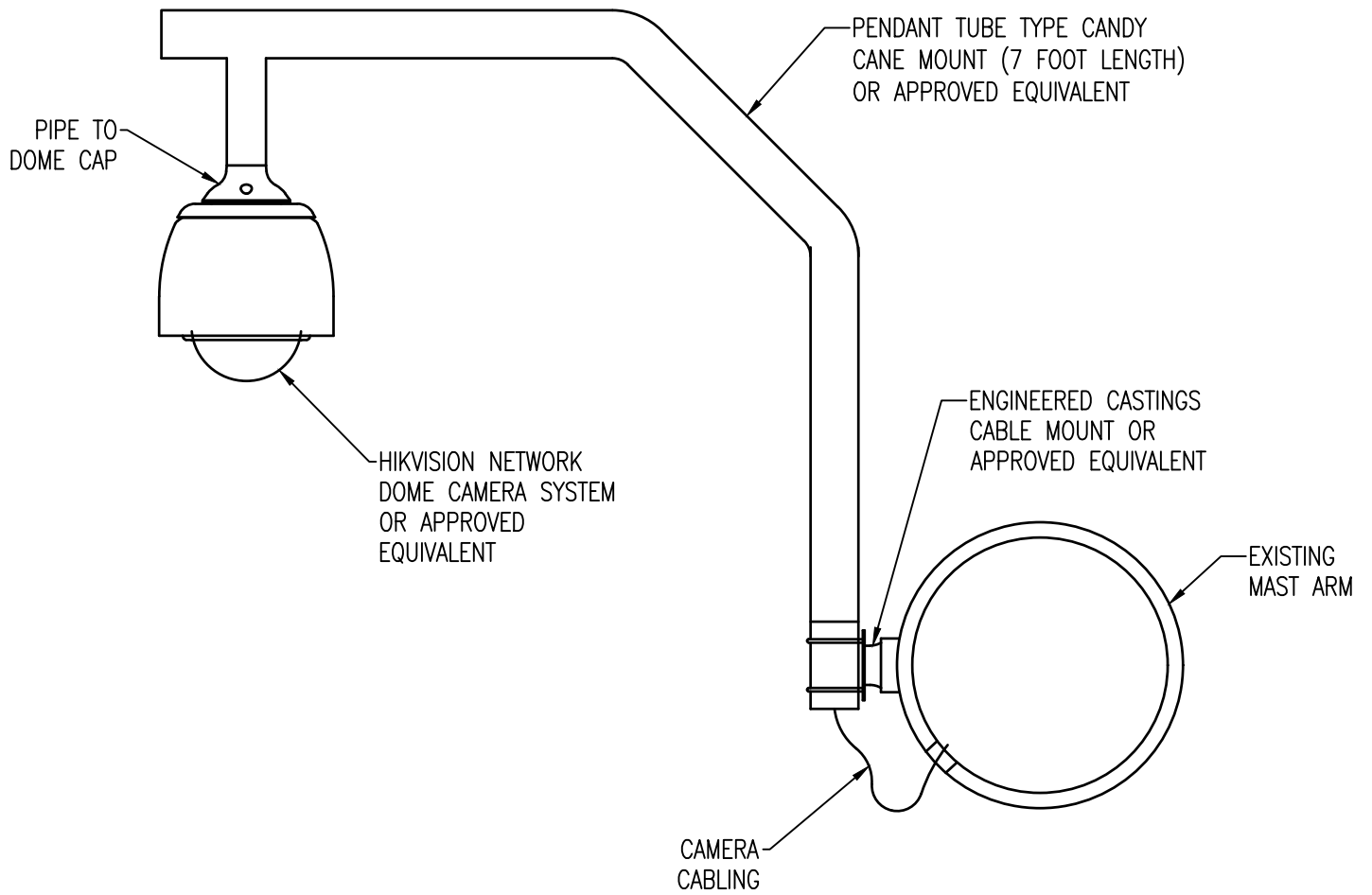

NOTES:

1. CAMERA SYSTEM COMPONENTS AND INSTALLATION ON MAST ARM SHALL BE APPROVED BY COUNTY ENGINEER.
2. CCTV CABINETS, FIBER OPTIC PULL BOXES, AND CONDUIT INSTALLATION SHALL BE PER COUNTY STANDARDS.



MARTIN COUNTY PUBLIC WORKS - STANDARD DETAILS

CCTV (MAST ARM MOUNT)

DETAIL

R-180A

DATE: 04/23/19

BOSCH LTC 9230/00 PARAPET
MOUNT OR APPROVED EQUIVALENT

PIPE TO
DOME CAP

HIKVISION NETWORK
DOME CAMERA SYSTEM
OR APPROVED
EQUIVALENT

EXISTING CONCRETE
STRAIN POLE

APPROVED
BAND MOUNT

SERVICE HEAD

CAMERA CABLING
(SECURE TO POLE)

2" RIGID GALVANIZED
CONDUIT TO BE
INSTALLED

NOTES:

1. CAMERA SYSTEM COMPONENTS AND INSTALLATION ON MAST ARM SHALL BE APPROVED BY COUNTY ENGINEER.
2. CCTV CABINETS, FIBER OPTIC PULL BOXES, AND CONDUIT INSTALLATION SHALL BE PER COUNTY STANDARDS.



MARTIN COUNTY PUBLIC WORKS - STANDARD DETAILS

CCTV (CONCRETE POLE MOUNT)

DETAIL

R-180B

DATE: 04/23/19

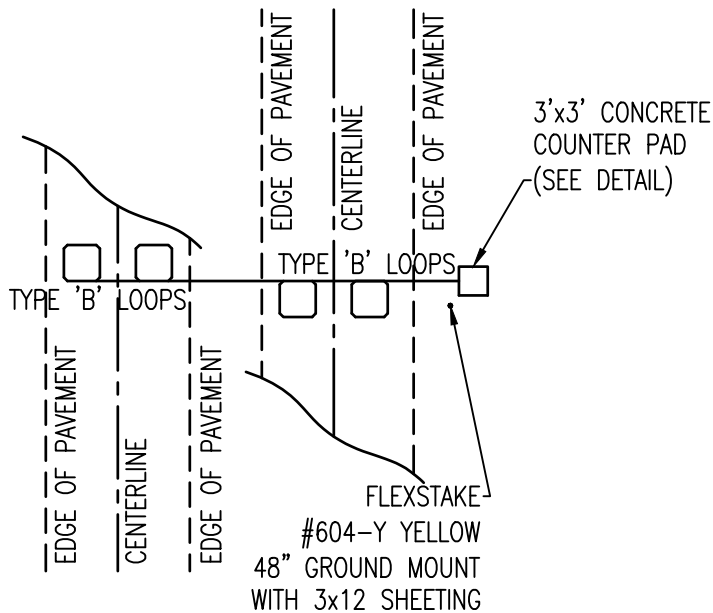

MULTI-LANE LAYOUT

SEMI-PERMANENT

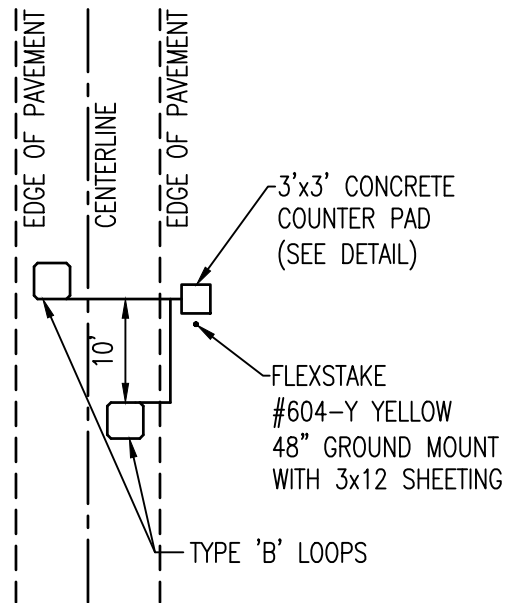

2-LANE LAYOUT

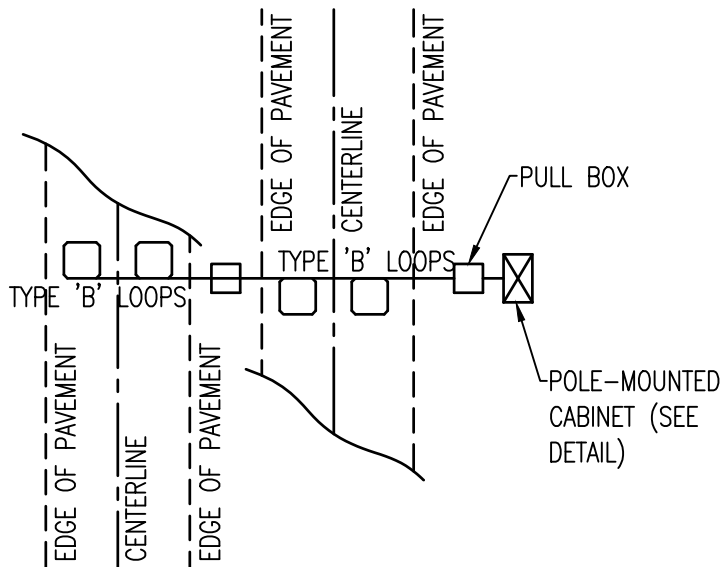

MULTI-LANE LAYOUT

PERMANENT

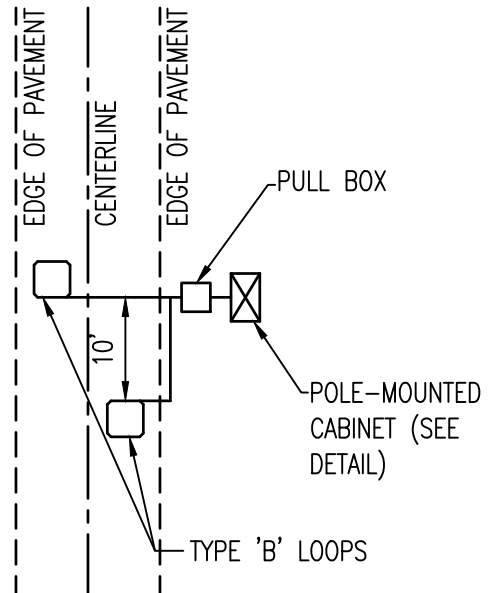

2-LANE LAYOUT

NOTES:

1. INSTALLATION LOCATION SHALL BE APPROVED BY COUNTY TRAFFIC DIVISION.
2. THE MAINTAINING AGENCY IS MARTIN COUNTY. THE CONTRACTOR IS RESPONSIBLE FOR TRAFFIC CONTROL PLAN THROUGH WORK ZONES IN ACCORDANCE WITH THE LATEST EDITION OF THE FDOT STANDARDS FOR DESIGN, CONSTRUCTION, MAINTENANCE AND UTILITY OPERATIONS ON THE STATE HIGHWAY SYSTEM (600 SERIES INDEX NUMBERS).
3. COMPONENTS FOR INSTALLATION SHALL BE APPROVED BY COUNTY TRAFFIC DIVISION.
4. THE CONTRACTOR SHALL NOTIFY THE COUNTY TRAFFIC DIVISION (772) 288-5528 AT LEAST 48 HOURS IN ADVANCE OF WORK BEING STARTED ON THE PROJECT.



MARTIN COUNTY PUBLIC WORKS - STANDARD DETAILS

TRAFFIC MONITORING SITE (LAYOUT)

DETAIL

R-190A

DATE: 04/23/19

HEAVY DUTY ANCHOR HINGE (TYP.) TO
CHAIN COUNTER TO CONCRETE PAD

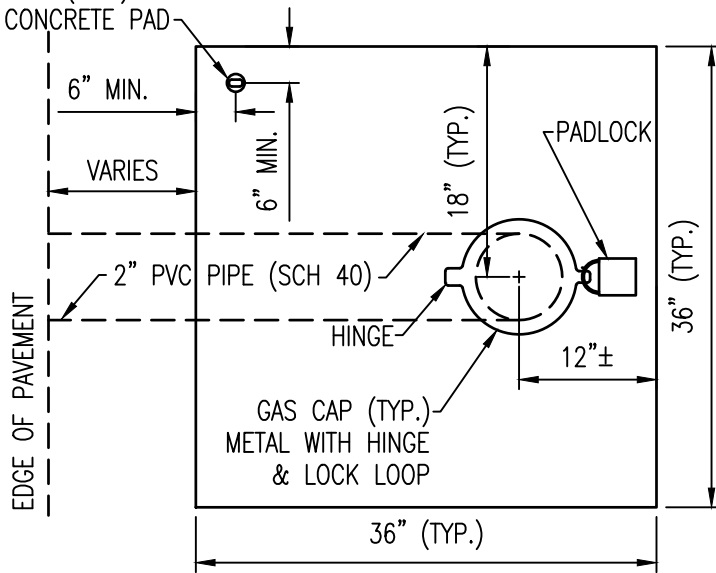

TOP VIEW

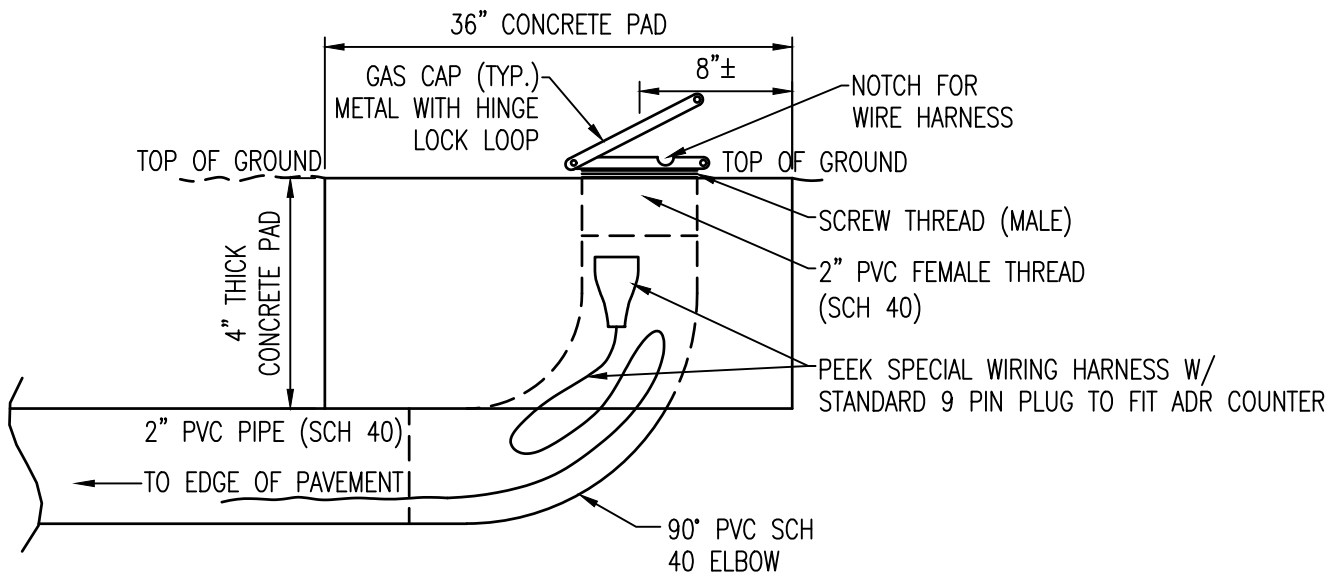

SIDE VIEW



MARTIN COUNTY PUBLIC WORKS - STANDARD DETAILS

TRAFFIC MONITORING SITE (COUNTER PAD)

DETAIL

R-190B

DATE: 04/23/19

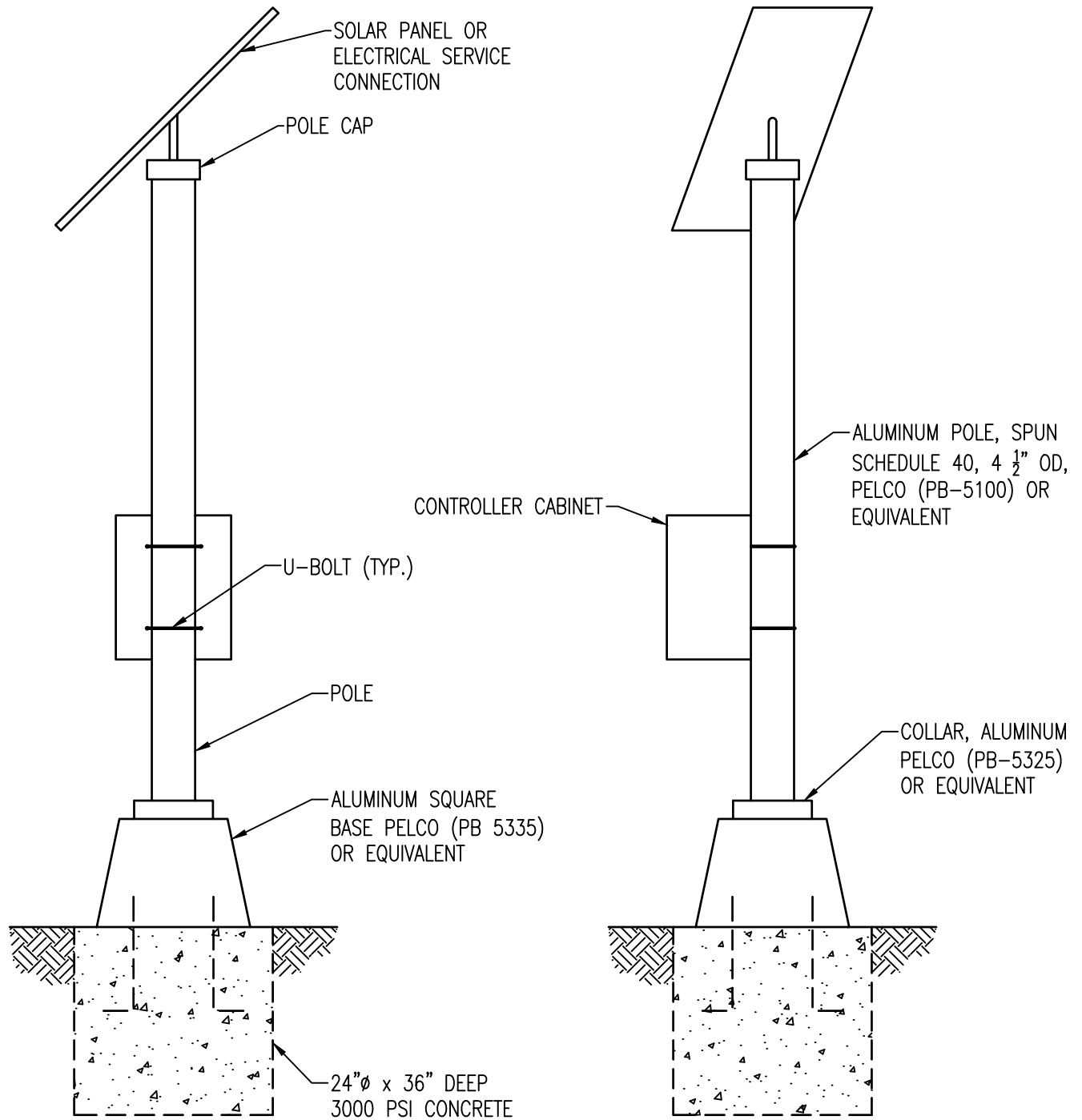

FRONT VIEW

SIDE VIEW

NOTES:

1. ALL FASTENERS TO BE STAINLESS STEEL.



MARTIN COUNTY PUBLIC WORKS - STANDARD DETAILS

TRAFFIC MONITORING SITE (POLE-MOUNTED CABINET)

DETAIL

R-190C

DATE: 04/23/19

PERMANENT POLE-MOUNTED TRAFFIC MONITORING SITE ASSEMBLY NOTES:

1. POLE-MOUNTED CABINET TO BE TYPE II 27"H X 15"W X 12"D WITH 3 POINT LATCHING, ONE FIXED SHELF, RAIN HOOD, SURGE ARRESTORS ON ALL INPUTS, AND COMPLETELY WIRED FOR SPECIFIED TRAFFIC COUNTER.
2. SOLAR PANEL TO HAVE A MINIMUM OUTPUT OF 20 WATTS.
3. MODEM MUST HAVE LOW POWER CONSUMPTION, BE DESIGNED FOR SOLAR POWER APPLICATIONS, AND BE COMPATIBLE WITH INTERNATIONAL ROAD DYNAMICS (I.R.D.) TRS TRAFFIC COUNTER AND ROAD REPORTER SOFTWARE.
4. TRAFFIC COUNTER SHALL BE IRD TRS ORT/8L WITH 12V DC POWER OUT OPTION AND MS CONNECTORS.
5. TRAFFIC COUNTER TO BE COMPATIBLE WITH I.R.D. ROAD REPORTER SOFTWARE.

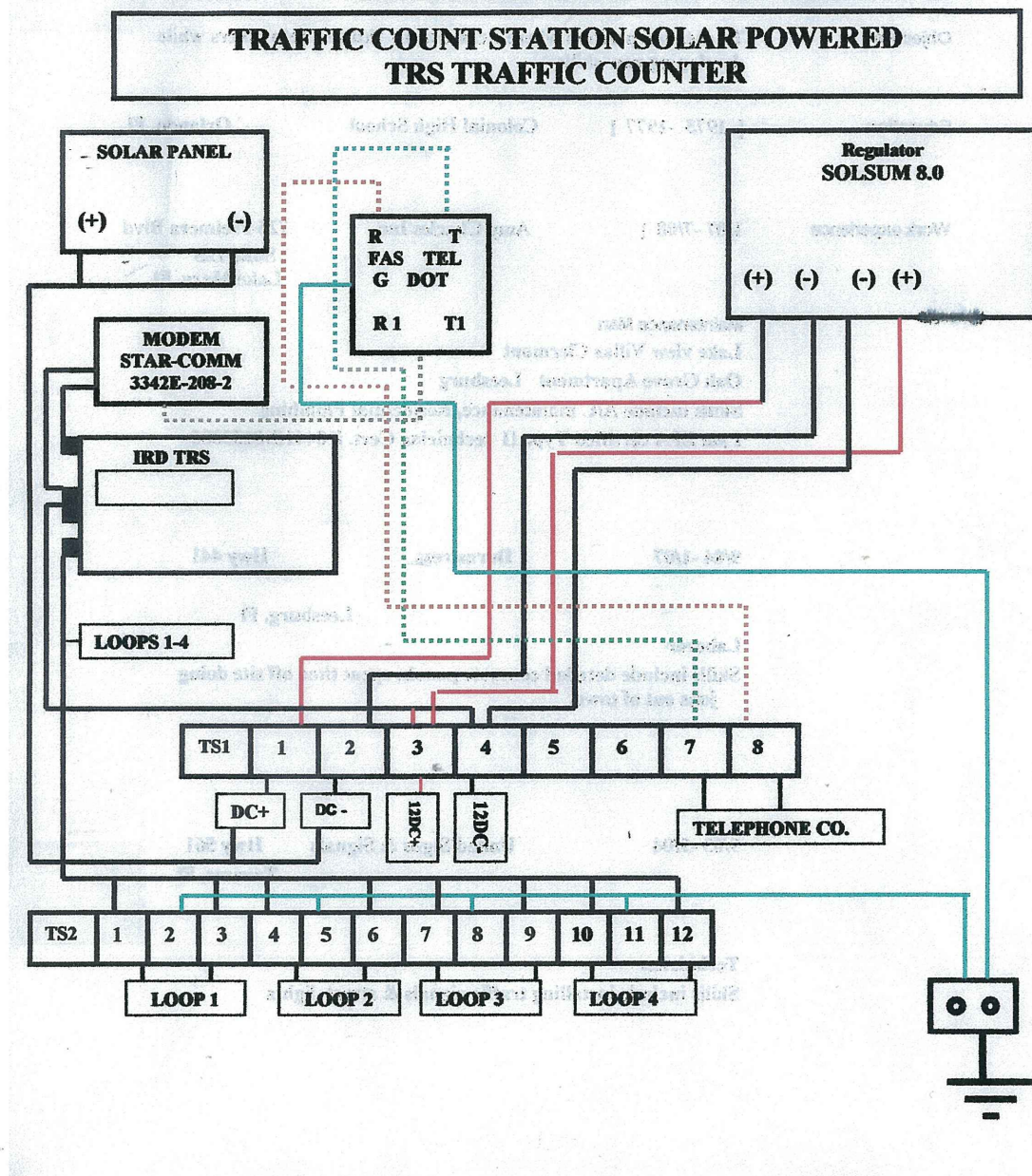

MARTIN COUNTY PUBLIC WORKS - STANDARD DETAILS

TRAFFIC MONITORING SITE (POLE-MOUNTED CABINET)

DETAIL

R-190D

DATE: 04/23/19

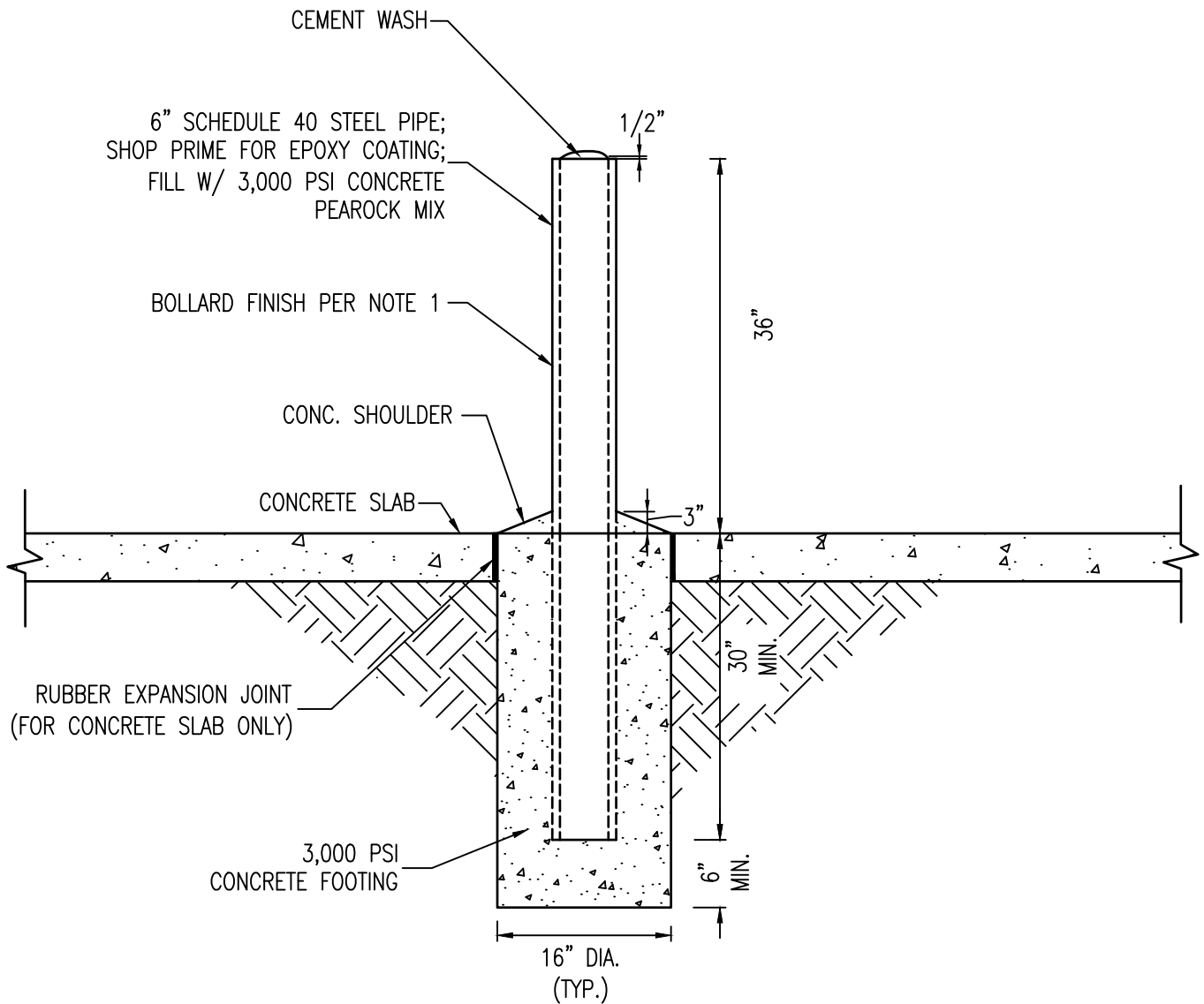

NOTE:

1. BOLLARD FINISH SHALL HAVE A PVC COVER OR ENAMEL PAINT. COLOR SHALL BE "SAFETY YELLOW" WITH A MINIMUM OF TWO (2) RETROREFLECTIVE BANDS.



MARTIN COUNTY PUBLIC WORKS - STANDARD DETAILS

FIXED BOLLARD

DETAIL

P-15

DATE: 04/23/19

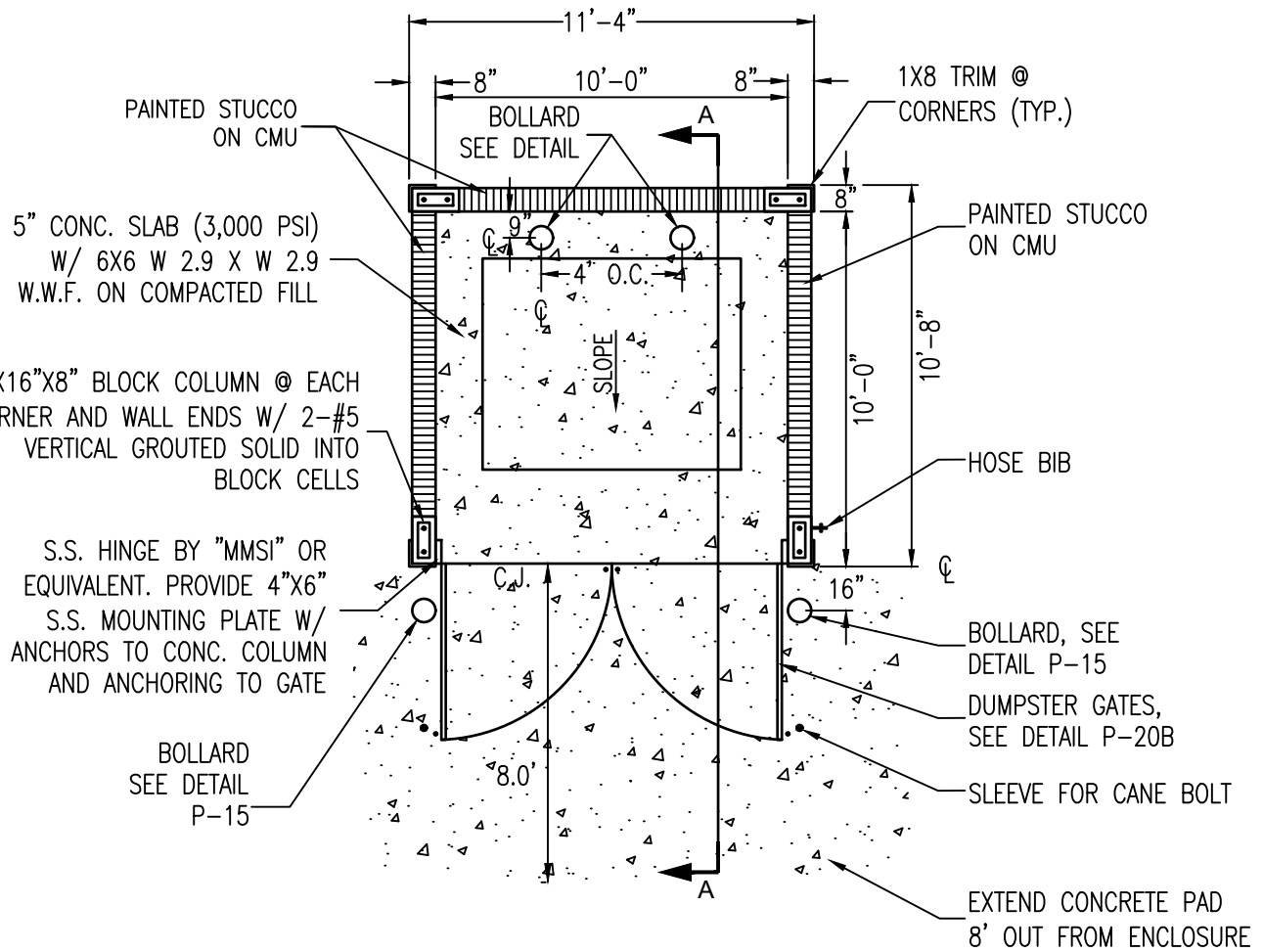

PLAN VIEW
N.T.S.



MARTIN COUNTY PUBLIC WORKS - STANDARD DETAILS

DUMPSTER ENCLOSURE

DETAIL

P-20A

DATE: 04/23/19

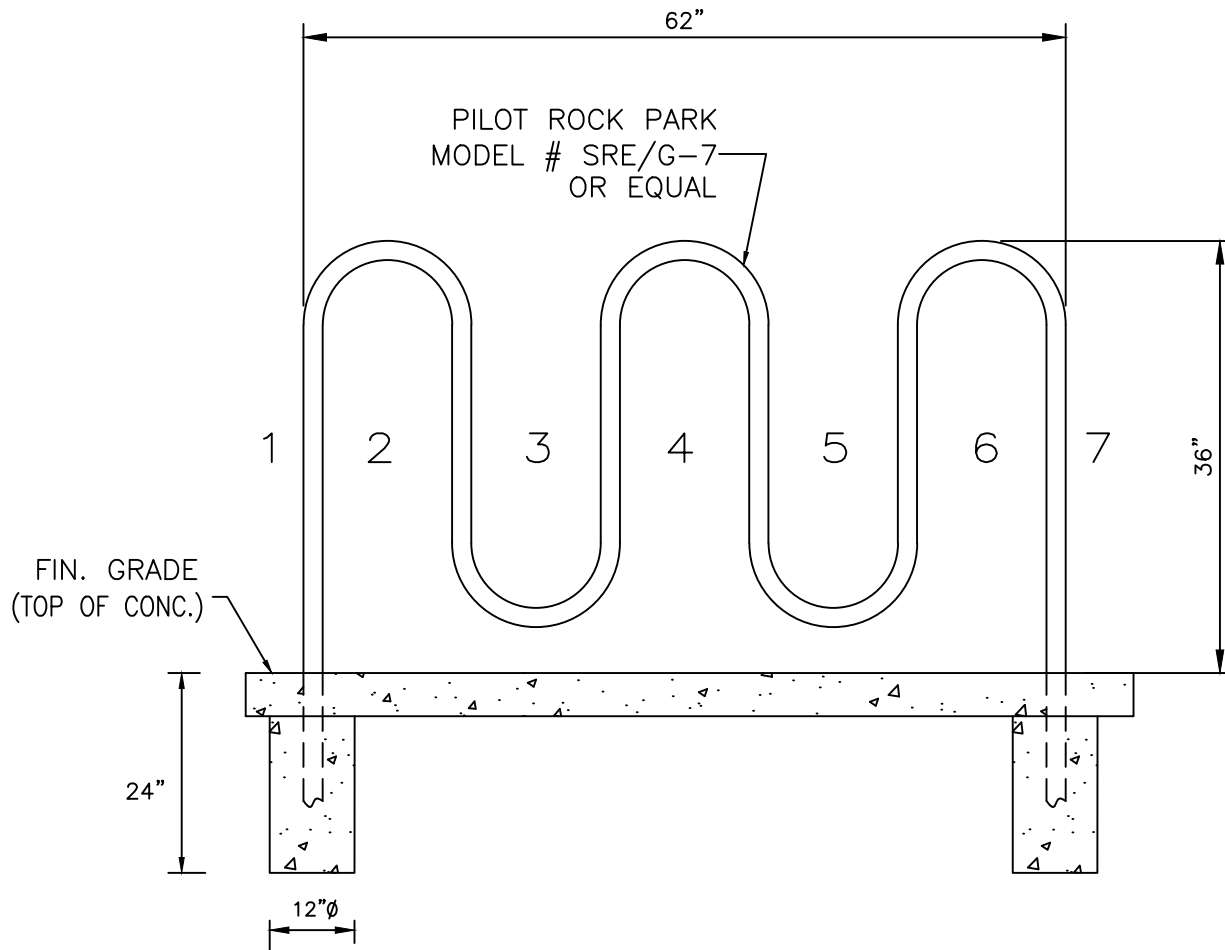

NOTES:

- BIKE RACK SHALL BE EMBEDDED A INTO A 24" DEEP, 12" DIAMETER CONCRETE FOOTER



MARTIN COUNTY PUBLIC WORKS - STANDARD DETAILS

BICYCLE RACK

DETAIL

P-30

DATE: 04/23/19

ALUMINUM SIGN
WITH VANDAL
PROOF BOLTS

2"

ALUMINUM CAP

4'-0"

2"X2" ALUMINUM POST
PAINTED BLACK

FINISHED GRADE

2'-0"

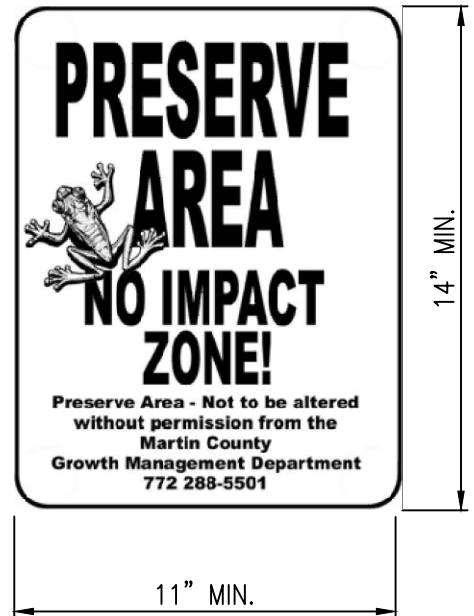

NOTE: SIGNS TO BE INSTALLED AT A FREQUENCY OF ONE EVERY 500 FEET ON CENTER AT MINIMUM; HOWEVER ONE SIGN EVERY 200 FOOT ON CENTER IS RECOMMENDED.

NOTES:

1. THE STRUCTURAL INTEGRITY OF THE SIGNS SHALL BE THE RESPONSIBILITY OF THE SIGN MANUFACTURER.
2. THE CONTRACTOR SHALL PROVIDE SHOP DRAWINGS FOR FABRICATION.
3. FASTENERS AND ATTACHMENTS SHALL BE NON-CORROSIVE AND NON-CONDUCTIVE AND INSULATED WHEN JOINING NON-COMPATIBLE MATERIALS.
4. COLORS SHALL BE SELECTED BY THE OWNER.
5. ALL SIGNS AND COMPONENTS SHALL BE OF TOP QUALITY WORKMANSHIP AND MATERIALS, AND BE FREE OF DEFECTS. DEFECTIVE IS DEFINED TO INCLUDE DELAMINATION, ABNORMAL DETERIORATION, FADING AND DISCOLORATION, WEATHERING, FAILURE OF SECURING TO SUBSTRATES, CRACKING, CORROSION, OR COATING DAMAGE, OR VISIBLE SCRATCHES ON THE SURFACE.
6. SIGNAGE SHALL NOT BEAR MANUFACTURER'S CODE OR OTHER IDENTIFYING MARKS ON ANY AREA OR PART WHICH MAY BE VISIBLE TO THE NORMAL POSITION, ATTITUDE, OR USE OF THE SIGN ITEM.
7. PROVIDE SCALED DRAWINGS OF ALL ELEMENTS AND ACTUAL PAINTED SAMPLES OF ALL MATERIALS FOR APPROVAL.
8. ALL SIGNS SHALL BE CONSTRUCTED OF VANDAL-RESISTANT CONSTRUCTION MATERIALS, METHODS, AND ATTACHMENTS.



MARTIN COUNTY PUBLIC WORKS - STANDARD DETAILS

PRESERVE AREA SIGN

DETAIL

P-40

DATE: 04/23/19

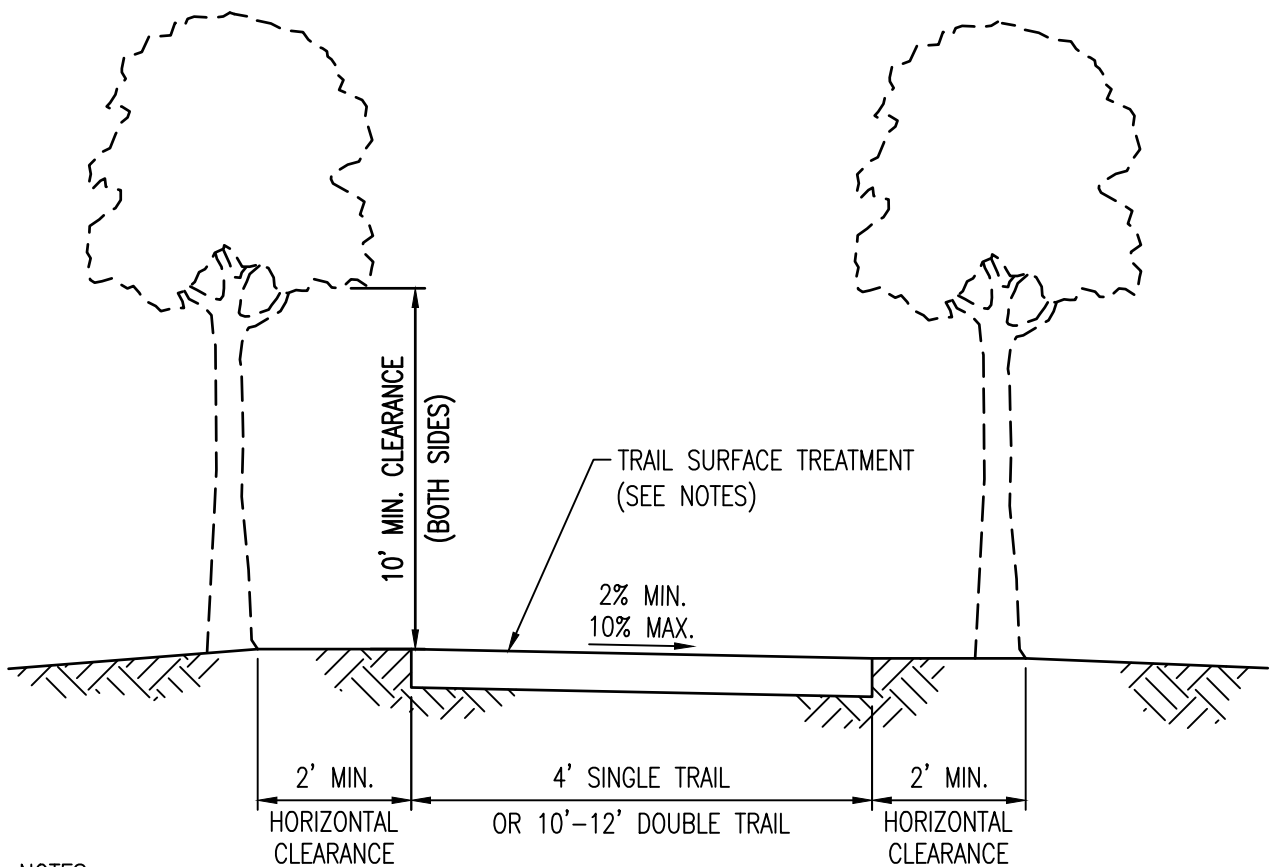

GENERAL NOTES:

1. ACCEPTABLE SURFACE TREATMENTS FOR EQUESTRIAN TRAILS INCLUDE SEED & MULCH, CRUSHED COQUINA, OR NATURAL EARTH.
2. CLEARANCE FROM VEGETATION & OBSTRUCTIONS SHALL BE 2 FEET ON EACH SIDE OF THE TRAIL.
3. A VERTICAL CLEARANCE OF 10' MINIMUM FROM VEGETATION & OBSTRUCTIONS SHALL BE MAINTAINED.
4. ALL REPAIR, REPLACEMENT, AND BROKEN GLASS REMOVAL SHALL BE PERFORMED AS SOON AS POSSIBLE.

SPECIFIC TRAILS CRITERIA FOR MAINTAINING AGENCY

1. MILD TRAILS
 - A. SURFACES ARE HARD (PAVED OR WOODEN); POTHOLES, ROOT DAMAGES, EROSION, & WASHOUTS ARE REPAIRED.
 - B. THERE IS NO TREE OR SHRUB ENCROACHMENT.
 - C. MISSING AND/OR DAMAGED SIGNS ARE REPLACED/REPAIRED.
 - D. LITTER IS COLLECTED WEEKLY; BROKEN GLASS IS REMOVED.
2. MEDIUM TRAILS
 - A. SURFACES HAVE MINIMAL TRIP FACTORS.
 - B. MULCH OR SHELL ROCK IS ADEQUATE.
 - C. THERE IS MINIMAL TREE OR SHRUB ENCROACHMENT.
 - D. EROSION AND/OR WASHOUTS ARE REPAIRED.
 - E. MISSING AND/OR DAMAGED SIGNS ARE REPLACED/REPAIRED.
 - F. LITTER IS COLLECTED AT LEAST TWICE WEEKLY; BROKEN GLASS IS REMOVED.
3. AGGRESSIVE TRAILS
 - A. SURFACES ARE NATURAL
 - B. TREE AND SHRUB ENCROACHMENT ARE LEFT NATURAL.
 - C. EROSION IS LEFT NATURAL BUT SHOULD NOT INTERFERE WITH TRAIL UTILIZATION.
 - D. MISSING AND/OR DAMAGED SIGNS ARE REPLACED/REPAIRED.
 - E. LITTER IS COLLECTED AT LEAST TWICE MONTHLY; BROKEN GLASS IS REMOVED.



MARTIN COUNTY PUBLIC WORKS - STANDARD DETAILS

EQUESTRIAN TRAIL

DETAIL

P-50

DATE: 04/23/19

6" X 6" PRESSURE-TREATED SOUTHERN YELLOW PINE #2 GRADE GROUND CONTACT 0.60 PER CUBIC FT. RETENTION

2" X 8" PRESSURE-TREATED SOUTHERN YELLOW PINE #1 GRADE GROUND CONTACT 0.60 PER CUBIC FT. RETENTION

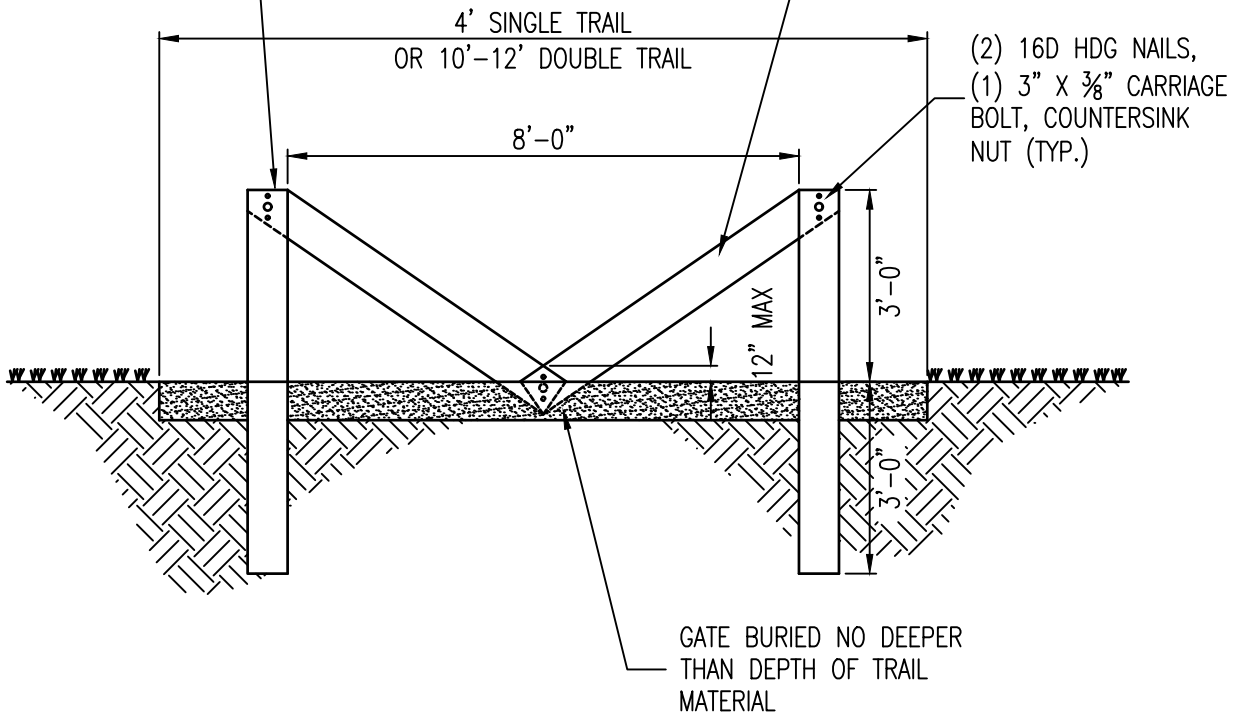

NOTES:

1. ALL HARDWARE SHALL BE HOT-DIPPED GALVANIZED (HDG).
2. DO NOT CUT OR GRIND HARDWARE.
3. BOLTS SHALL NOT PROJECT BEYOND FACE OF POST.
4. PRESSURE TREATMENT SHALL BE ALKALINE COPPER QUAT (ACQ).



MARTIN COUNTY PUBLIC WORKS - STANDARD DETAILS

EQUESTRIAN TRAIL - 'V' GATE

DETAIL

P-51

DATE: 04/23/19

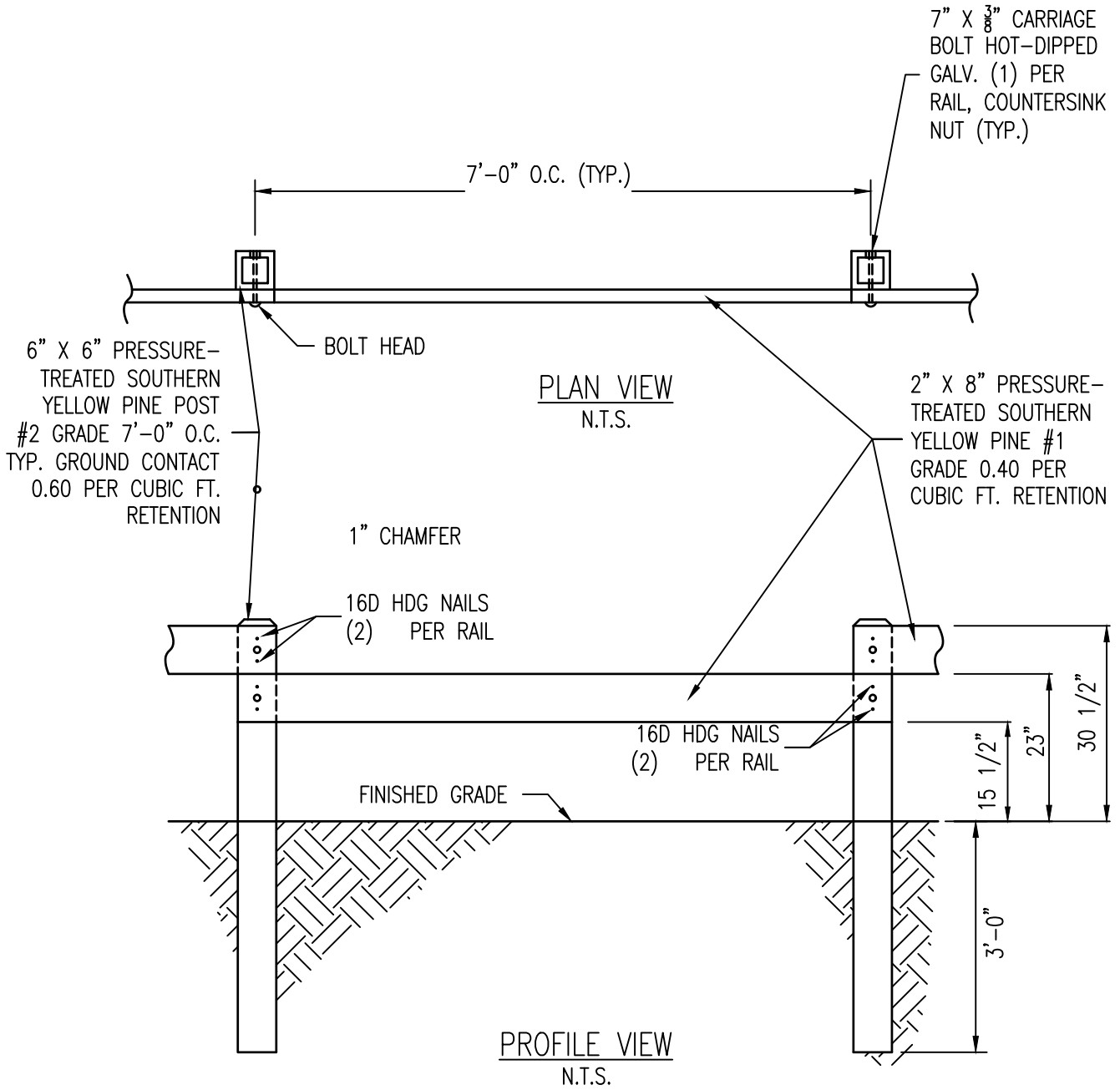

NOTES:

1. ALL HARDWARE SHALL BE HOT-DIPPED GALVANIZED (HDG).
2. DO NOT CUT OR GRIND HARDWARE.
3. BOLTS SHALL NOT PROJECT BEYOND FACE OF POST.
4. PRESSURE TREATMENT SHALL BE ALKALINE COPPER QUAT (ACQ).



MARTIN COUNTY PUBLIC WORKS - STANDARD DETAILS

POST AND RAIL FENCE

DETAIL

P-60

DATE: 04/23/19

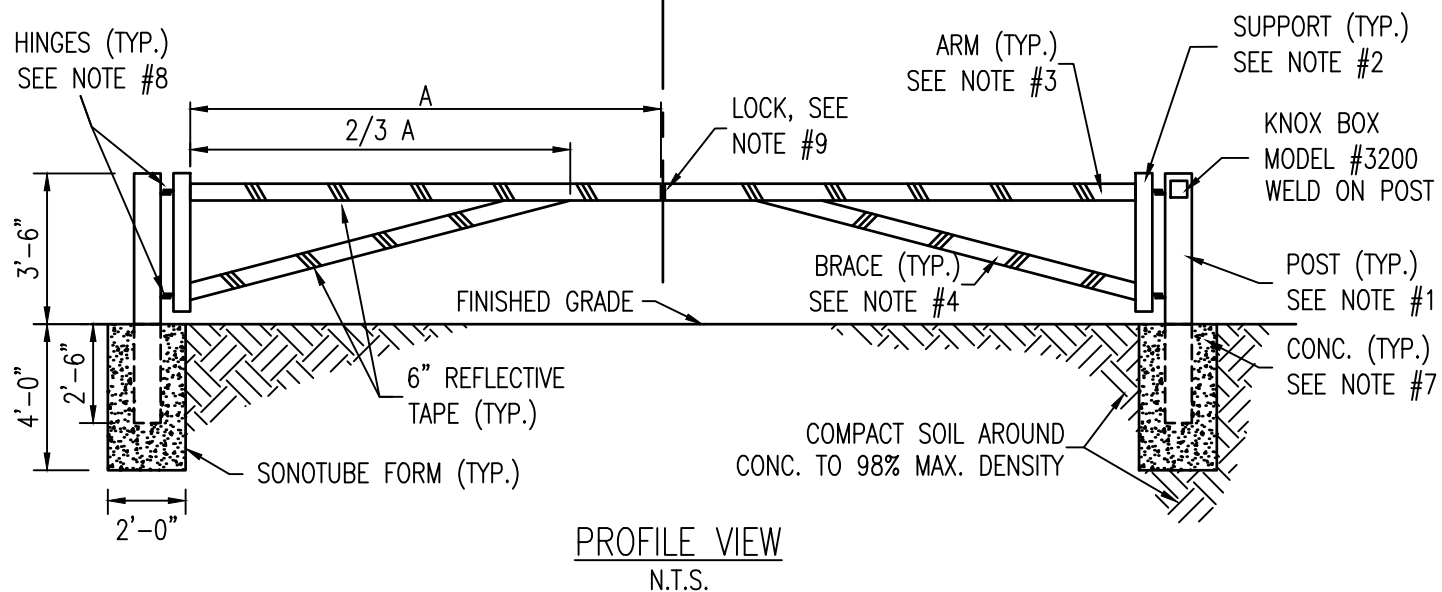
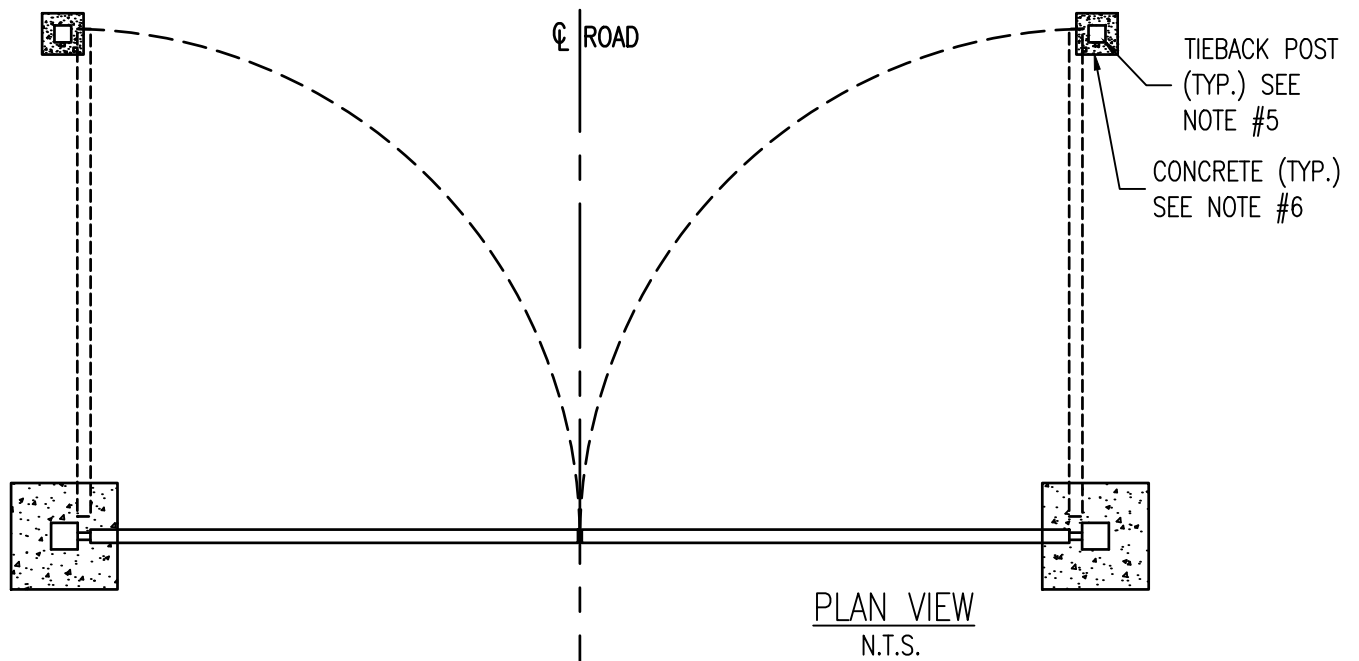

NOTES:

1. POST: STEEL TUBING (TS) $\frac{1}{4}$ "x6"x6"x6'-0", ASTM A500, GR. B, PRIMED AND PAINTED.
2. SUPPORT: TS $\frac{1}{4}$ "x3"x3"x3'-0" LONG, ASTM A500, GR. B, PRIMED AND PAINTED.
3. ARM: LENGTH VARIES. 20 FOOT AVERAGE FOR DOUBLE LEAF GATE ('A' WOULD EQUAL 10 FOOT). TS $\frac{1}{4}$ "x3"x3"x20'-0", ASTM A500, GR. B, PRIMED AND PAINTED.
4. BRACE: TS $\frac{3}{16}$ "x3"x3", ASTM A500, GR. B, PRIMED AND PAINTED.
5. TS $\frac{3}{16}$ "x3"x3"x6'-0". NOTE: TWO (2) TIE-BACK POSTS ARE REQUIRED. TIE-BACK POST FOR EACH LEAF IN OPEN POSITION.
6. 3,000 PSI CONCRETE OR APPROX. FOUR (4) BAGS OF "SAKRETE" MIX PER TIE-BACK POST.
7. 3,000 PSI CONCRETE OR 10 TO 12 BAGS "SAKRETE" MIX PER POST.
8. HINGE MATERIAL: 5"x4"x $\frac{3}{4}$ " ALUMINUM FLAT BAR. PINS: $\frac{7}{8}$ " STAINLESS STEEL WITH 1" x $\frac{7}{8}$ " DRY BUSHINGS WITH STAINLESS STEEL COLLARS ON TOP. PINS ARE SECURED AT BOTTOM TO PREVENT REMOVAL.
9. APPLICANT SHALL SUBMIT DRAWINGS OF LOCK, SIGNED AND SEALED BY A FL. P.E. TO BE APPROVED BY THE COUNTY.



MARTIN COUNTY PUBLIC WORKS - STANDARD DETAILS

POST AND RAIL FENCE - DOUBLE SWING GATE

DETAIL

P-61

DATE: 04/23/19

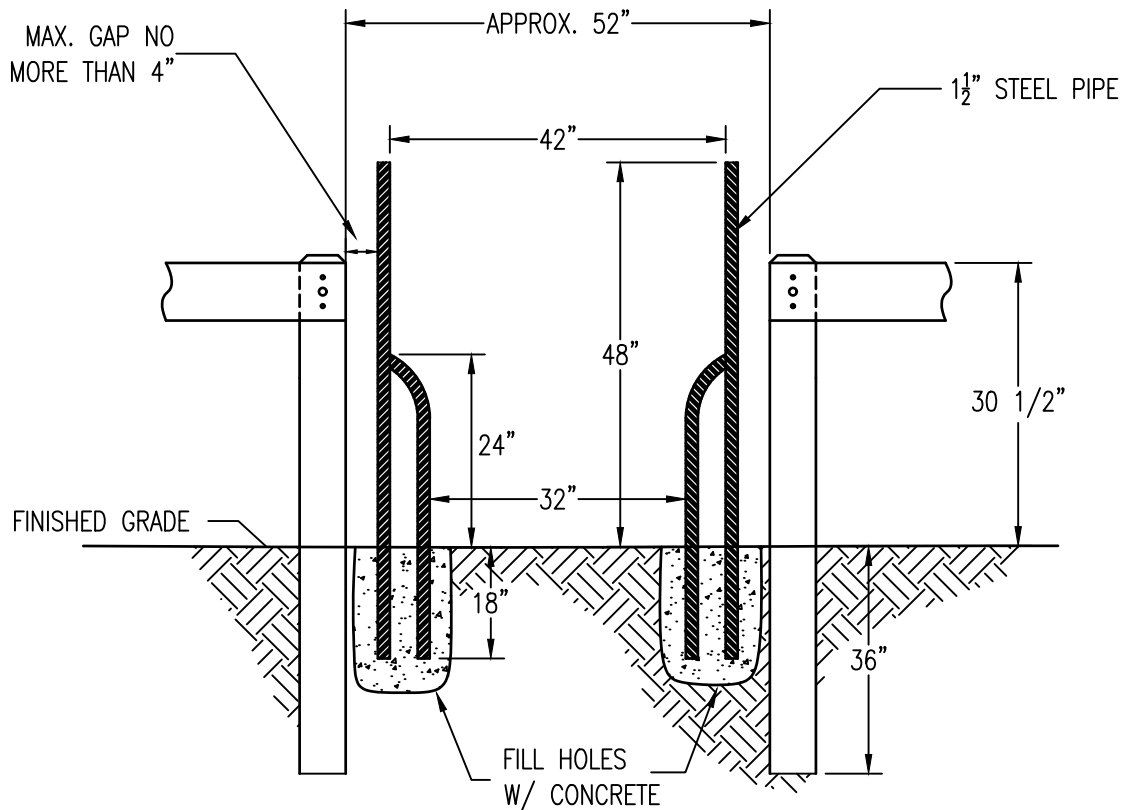

PROFILE VIEW
N.T.S.

NOTES:

1. THE 32" INSIDE WIDTH IS CRITICAL FOR SAFETY AND A.D.A. REQUIREMENTS.
2. USE ASTM A53 1 1/2" SCHEDULE 40 STEEL PIPE (1.9" O.D. X .145 WALL).
3. THE PRODUCT SHALL BE HOT-DIPPED GALVANIZED AFTER FABRICATION AND THEN HAND FILED TO REMOVE GALVANIZING FLASH.
4. 3,000 PSI CONCRETE OR 2-3 BAGS "SAKRETE" MIX PER HOLE.



MARTIN COUNTY PUBLIC WORKS - STANDARD DETAILS

POST AND RAIL FENCE - FENCE OPENING

DETAIL

P-62

DATE: 04/23/19